



1STC802006D0201



**Алматы** (7273)495-231  
**Ангарск** (3955)60-70-56  
**Архангельск** (8182)63-90-72  
**Астрахань** (8512)99-46-04  
**Барнаул** (3852)73-04-60  
**Белгород** (4722)40-23-64  
**Благовещенск** (4162)22-76-07  
**Брянск** (4832)59-03-52  
**Владивосток** (423)249-28-31  
**Владикавказ** (8672)28-90-48  
**Владимир** (4922)49-43-18  
**Волгоград** (844)278-03-48  
**Вологда** (8172)26-41-59  
**Воронеж** (473)204-51-73  
**Екатеринбург** (343)384-55-89

**Иваново** (4932)77-34-06  
**Ижевск** (3412)26-03-58  
**Иркутск** (395)279-98-46  
**Казань** (843)206-01-48  
**Калининград** (4012)72-03-81  
**Калуга** (4842)92-23-67  
**Кемерово** (3842)65-04-62  
**Киров** (8332)68-02-04  
**Коломна** (4966)23-41-49  
**Кострома** (4942)77-07-48  
**Краснодар** (861)203-40-90  
**Красноярск** (391)204-63-61  
**Курск** (4712)77-13-04  
**Курган** (3522)50-90-47  
**Липецк** (4742)52-20-81

**Магнитогорск** (3519)55-03-13  
**Москва** (495)268-04-70  
**Мурманск** (8152)59-64-93  
**Набережные Челны** (8552)20-53-41  
**Нижегород** (831)429-08-12  
**Новокузнецк** (3843)20-46-81  
**Ноябрьск** (3496)41-32-12  
**Новосибирск** (383)227-86-73  
**Омск** (3812)21-46-40  
**Орел** (4862)44-53-42  
**Оренбург** (3532)37-68-04  
**Пенза** (8412)22-31-16  
**Петрозаводск** (8142)55-98-37  
**Псков** (8112)59-10-37  
**Пермь** (342)205-81-47

**Ростов-на-Дону** (863)308-18-15  
**Рязань** (4912)46-61-64  
**Самара** (846)206-03-16  
**Санкт-Петербург** (812)309-46-40  
**Саратов** (845)249-38-78  
**Севастополь** (8692)22-31-93  
**Саранск** (8342)22-96-24  
**Симферополь** (3652)67-13-56  
**Смоленск** (4812)29-41-54  
**Сочи** (862)225-72-31  
**Ставрополь** (8652)20-65-13  
**Сургут** (3462)77-98-35  
**Сыктывкар** (8212)25-95-17  
**Тамбов** (4752)50-40-97  
**Тверь** (4822)63-31-35

**Тольятти** (8482)63-91-07  
**Томск** (3822)98-41-53  
**Тула** (4872)33-79-87  
**Тюмень** (3452)66-21-18  
**Ульяновск** (8422)24-23-59  
**Улан-Удэ** (3012)59-97-51  
**Уфа** (347)229-48-12  
**Хабаровск** (4212)92-98-04  
**Чебоксары** (8352)28-53-07  
**Челябинск** (351)202-03-61  
**Череповец** (8202)49-02-64  
**Чита** (3022)38-34-83  
**Якутск** (4112)23-90-97  
**Ярославль** (4852)69-52-93

Россия +7(495)268-04-70

Казахстан +7(7172)727-132

Киргизия +996(312)96-26-47

<https://abbenclosures.nt-rt.ru/> || [aua@nt-rt.ru](mailto:aua@nt-rt.ru)

# Contents

▶	<b>1 Standards relative to switchgear and applicability</b> .....	2
	1.1 The IEC 60439-1 Standard .....	3
	<b>2 Nominal electrical characteristics of switchgear</b> .....	4
	<b>3 Classification of electric switchgear</b>	
	3.1 Open switchgear and closed switchgear .....	7
	3.2 External configuration .....	7
	3.3 Installation conditions .....	7
	3.4 Functional classification .....	8
	<b>4 IP degree of protection in switchgear</b> .....	9
	4.1 IP degree of protection in ArTu switchgear .....	10
	4.2 IP degree of protection and installation environment .....	11
	4.3 IP degree of protection and heating .....	12
	<b>5 Degrees of IK protection of the housings</b>	
	5.1 IK degree of protection in ArTu switchgear .....	13
	<b>6 Forms of segregation</b> .....	14
▶	<b>7 Checking the overtemperature limits inside ArTu switchgear</b>	
	7.1 Introduction .....	15
	7.2 Thermal verification and certification of ABB SACE ArTu switchgear .....	16
	7.3 Checking procedure .....	18
	7.4 Extracts from test certificates .....	23
▶	<b>8 Protection against effects of short-circuit</b>	
	8.1 Checking short-circuit withstand current .....	44
	8.2 Short-circuit current and suitability of the switchgear for the plant .....	45
	8.3 Selection of the distribution system in relation to the short-circuit withstand current .....	47
	<b>9 Protection against electric shocks</b>	
	9.1 Protection against direct contacts .....	51
	9.2 Protection against indirect contacts .....	51
▶	<b>10 Practical indications for construction of the switchgear</b>	
	10.1 Positioning the circuit-breakers .....	54
	10.2 Anchoring the conductors near the circuit-breakers .....	56
	<b>11 Guide to certification according to the Standard IEC 60439-1</b>	
	11.1 Introduction .....	61
	11.2 Type tests and checks .....	62
	11.3 Individual tests and checks (acceptance test of the switchgear) .....	64
	<b>12 Example of construction of ArTu switchgear</b>	
	12.1 Single-line diagram .....	68
	12.2 Selection of the circuit-breakers and of the ducts outside the switchgear .....	69
	12.3 Front of switchgear, distribution system and structure .....	69
	12.4 Conformity with Standard IEC 60439-1 .....	72
▶	<b>Annex A:</b>	
	LOVAG ACAE certificates .....	74
▶	<b>Annex B:</b>	
	Forms for the declaration of conformity and acceptance test .....	92

GENERAL  
STANDARDS AND  
CHARACTERISTICS

VERIFYING THE  
OVERTEMPÉRATURES

PROTECTION AGAINST  
SHORT-CIRCUIT AND  
ELECTRIC SHOCKS

PRACTICAL INDICATIONS  
CERTIFICATION AND  
CONSTRUCTION

CERTIFICATES

DECLARATION OF  
CONFORMITY

## 1 Standards relative to switchgear and their applicability

Electric switchgear must be considered a component of the electrical installation in the same way as a circuit-breaker or a plug socket. It is made up of several pieces of switchgear and controlgear assemblies grouped into one or more adjacent enclosures (columns).

In switchgear you can find the enclosure - called housing by the standards (which carries out the mechanical supporting and protection function of the components it contains) - and the electrical equipment, consisting of the apparatus, the internal connections and the input and output terminals for connection to the plant.

This complex must be suitably assembled to satisfy the safety requirements and optimally fulfil the functions it is designed for.

From this point of view, the Low Voltage Directive 2006/95/CE (which replaces the 73/23/CE and following amendments) and the relative implementation regulation oblige the installer to sign a declaration of workmanlike conformity, for each part of the plant realized.

As known, the equipment and plants constructed in conformity with the IEC/EN standards are considered workmanlike. Therefore, like all the components of an electrical installation, the switchgear must also conform to the relative product Standard. At present this Standard is IEC 60439-1 (1999) + Am1 (2004) implemented at international level without any changes.

These standards apply to Low Voltage switchgear (whose rated voltage is not higher than 1000 V in alternating current with frequency no higher than 1000 Hz, or than 1500 V in direct current).

The IEC 60439-1 is the general part for the switchgear while the other parts refer to special pieces of switchgear and must be read together with the general part. These parts are:

- IEC 60439-2:** “Special prescriptions for busbar ducts”;
- IEC 60439-3:** “Special prescriptions for switchgear and controlgear assemblies intended to be installed in places where unskilled persons have access for their use. Distribution boards (ASD)”;
- IEC 60439-4:** “Special prescriptions for assemblies for construction sites (ASC)”;
- IEC 60439-5:** “Cable distribution cabinets”;

A further two CEI publications regarding electric switchgear are:

- IEC 60890** which is a method for determining the overtemperatures, by means of extrapolation, for PTTA switchgear;
- IEC 61117** which is a method for determining the short-circuit withstand current, by means of calculation, of PTTA switchgear.

**After an overview of the Standard, this guide deals with ArTu switchgear conforming to the IEC 60439-1 Standard.**

# 1 Standards relative to switchgear and its applicability

1.1 The IEC 60439-1 Standard

## 1.1 The IEC 60439-1 Standard

The IEC 60439-1 Standard establishes the requirements regarding construction, safety and possibility of maintenance of electric switchgear, identifying the rated characteristics, the ambient operating conditions, the mechanical and electrical requirements and prescriptions regarding performances.

Type and individual tests are also prescribed, as well as the methods for carrying them out and assessment criteria for the results.

The Standard requires the switchgear to be constructed in reference to a well-identified prototype, which has undergone all the type tests required by the Standard. With this statement, the Standard makes the reference prototype obligatory, but allows two types of products to be realized, defined as follows:

- Equipment constructed in series (TTA), totally conforming to the prototype which has undergone all the foreseen type tests.
- Equipment not constructed in series (PTTA), not fully conforming to the reference prototype.

For the ANS equipment, the Standard allows some of the tests to be replaced by using extrapolation, calculations or other methods which the manufacturer shows to be valid in order to verify the switchgear performances.

The checks made by means of calculation or simplified measurements, allowed as an alternative to the type tests, regard the following:

- heating,
- short-circuit withstand current,
- insulation.

The Standard allows some stages of the switchgear assembly to be carried out outside the manufacturer's workshop, but in any case following their instructions.

Installers can therefore use products marketed in assembly kits to realize the configuration of switchgear suitable for their purpose.

La Norma stessa indica una suddivisione delle responsabilità tra costruttore e assemblatore. The Standard itself indicates a division of responsibility between the manufacturer and the assembler according to table 7: "List of the checks and tests to be carried out on TTA and PTTA equipment", in which both the type tests and the individual tests to be carried out on the switchgear are defined:

The manufacturer must:

- carry out type tests which verify correspondence of the prototype with the prescriptions of the Standard
- provide the instructions for construction of the switchgear and for its assembly.

The assembler, on the other hand, is responsible for:

- selection and assembly of the components respecting the instructions provided
- having to ascertain correspondence with the Standard by means of the above-mentioned checks should
- the switchgear differ from the prototype tested having to carry out the individual tests on each piece made.

The distinction between TTA and PTTA switchgear carries no weight in the declaration of conformity with the Standard, since the switchgear must conform to it.

Below we indicate the list of type tests and individual tests prescribed by the Standard.

Type tests	Individual tests
<p>The Standard foresees the following type tests:</p> <ul style="list-style-type: none"> <li>• overtemperature limits</li> <li>• withstanding the applied voltage</li> <li>• short-circuit withstand current</li> <li>• efficiency of the protection circuit</li> <li>• insulation distances</li> <li>• degree of protection</li> <li>• mechanical operation</li> </ul>	<p>The Standard foresees the following individual tests:</p> <ul style="list-style-type: none"> <li>• visual inspection of the switchgear, including checking the cabling, and, if necessary, an electrical operation test</li> <li>• a dielectric test</li> <li>• checking the means of protection and the electrical efficiency of the protection circuit</li> </ul>

These tests can be carried out in any order.

*The fact that the individual tests are carried out in the manufacturer's factory does not exonerate the switchgear installer from checking these after transport and installation.*

## ▶ 2 Rated electrical characteristics of switchgear

The main electrical characteristics of switchgear are indicated below.

### **Rated operating voltage ( $U_e$ )**

This is the rated voltage value of a switchgear circuit which, together with its rated current, determines its use. For three-phase circuits this voltage corresponds to the line voltage between the phases.

Normally there is a main switchgear circuit, with its own rated voltage, and one or more auxiliary circuits with their own rated voltages.

The manufacturer must assign the voltage limits to be respected for correct operation of the circuits present inside the switchgear.

### **Rated insulation voltage ( $U_i$ )**

This is the voltage value of a circuit in switchgear to which the applied voltage tests, the distances in air and the surface distances refer.

The rated voltage of each circuit must not exceed its rated insulation voltage.



### **Rated impulse withstand voltage ( $U_{imp}$ )**

This is the peak value of an impulse voltage which a circuit can withstand under specific conditions; the distances in air are referred to this value. This value must be equal to or higher than the transient overvoltages which occur in the system where the equipment is inserted. From this point of view the IEC 60439-1 Standard proposes two tables:

- Table G1, given on the following page, indicates the preferential values of rated impulse withstand voltage at the different points of the plant according to the operating voltage towards earth;
- Table 13 provides the test voltage value corresponding to the impulse withstand voltage according to the altitude the test is carried out at.

## 2 Rated electric characteristics of switchgear

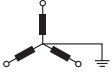
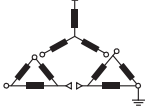
Correspondence between the rated voltage of the power supply system and the rated impulse withstand voltage, in the case of protection against overvoltages with surge arresters conforming to IEC 60099-1

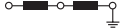
Maximum rated operating voltage value towards earth in AC (r.m.s. value) or DC [V]	Rated voltage of the power supply system (≤ of the rated insulation voltage of the equipment) [V]				Preferential values of the rated impulse withstand voltage [kV] (1.2 / 50 ms) at 2000 m			
					Overvoltage category			
					IV	III	II	I
	 Alternating current (r.m.s. value) AC r.m.s.	 Alternating current (r.m.s. value) AC r.m.s.	 Alternating current (r.m.s. value) or direct current AC r.m.s. or DC	 Alternating current (r.m.s. value) or direct current AC r.m.s. or DC	Initial installation level (operating input)	Initial distribution circuit level	Load level	Protected level
50	–	–	12,5; 24; 25 30; 42; 48	–	1,5	0,8	0,5	0,33
100	66/115	66	60	–	2,5	1,5	0,8	0,5
150	120/208 127/220	115; 120; 127	110; 120	220-110 240-120	4	2,5	1,5	0,8
300	230/380; 230/400; 240/415; 260/440; 277/480	220; 230 240; 260 277	220	440-220	6	4	2,5	1,5
600	347/600; 380/660; 400/690; 415/720; 480/830	347; 380; 400 415; 440; 480 500; 577; 600	480	960-480	8	6	4	2,5
1000	–	660; 690; 720; 830; 1000	1000	–	12	8	6	4

The values of rated impulse withstand voltage provided in the table are based on the operating characteristics of the surge arresters in accordance with IEC 60099-1.

For cases where control of the overvoltages is obtained by means other than by surge arresters, IEC 60364-4-443 provides the information about correlation between the rated voltage of the power supply system and the rated impulse withstand voltage of the equipment.

## ▶ 2 Rated electric characteristics of switchgear

### Rated current (I<sub>n</sub>)

This is the current value a circuit must carry maintaining the overtemperatures, in its parts, within the limits specified in the foreseen test conditions (see point 6).

### Short-time withstand current (I<sub>cw</sub>)

This is the r.m.s. value of short-circuit current which a circuit can withstand for a certain period of time (normally 1 second) under the set test conditions.

### Peak withstand current (I<sub>pk</sub>)

This is the peak value of the short-circuit current which the switchgear circuit can withstand during a certain time interval and under the set test conditions.

### Conditioned short-circuit current (I<sub>cc</sub>)

This is value of the prospective short-circuit current, fixed by the manufacturer, that the circuit, protected by protection apparatus against the short-circuit specified by the manufacturer, can withstand satisfactorily during the operating time of this apparatus under the specified test conditions.

### Rated contemporaneity factor

In the case of switchgear (or of a column) with different main circuits, this is the ratio between the maximum value of the sum, at any time, of the effective currents (I<sub>b</sub>) which pass through all the main circuits considered and the sum of the rated currents (I<sub>n</sub>) of all the main circuits of the switchgear or of the part of this column considered.

$$\text{rated contemporaneity factor} = \frac{\sum I_b}{\sum I_n}$$

When the manufacturer assigns a rated contemporaneity factor, this factor must be used for the overtemperature test, otherwise reference is made to the one indicated below recommended in the Standard.

Number of main circuits	Contemporaneity factor
2 and 3	0,9
4 and 5	0,8
from 6 to 9 (inclusive)	0,7
10 (and higher)	0,6

### Rated frequency

This is the value of the frequency the operating conditions refer to. If the circuits of switchgear are provided for other frequency values, the rated frequency of each circuit must be indicated.

## 3 Classification of electric switchgear

3.1 Open switchgear and closed switchgear - 3.2 External configuration- 3.3 Installation conditions

There are different classifications for electric switchgear, which depend on various factors: on the type of construction, on external configuration, on installation conditions and on the function carried out.

### 3.1 Open switchgear and closed switchgear

According to the type of construction, the IEC 60439-1 Standard first of all distinguishes between open and closed switchgear.

- **Closed**  
The switchgear is closed when it includes panels protected on all sides to guarantee a degree of protection against direct contacts not less than IPXXB (see chapter 4). The switchgear used in ordinary environments must be closed.
- **Open**  
Open switchgear, with or without front protection, are the so-called open switchgear, where live parts are accessible. This switchgear can only be used in electrical workshops, i.e. in places where trained personnel have access.

### 3.2 External configuration

From the viewpoint of external configuration, the switchgear is distinguished by being:

- **With cabinet (column)**  
Used for large distribution and control apparatus. By placing several cabinets side by side switchgear with multiple cabins is obtained.
- **With bench**  
Used for controlling machines or complex plants both in the mechanical industry sector and in those of the iron and steel or chemical industries.
- **With box**  
Characterized by wall mounting both extending and embedded. This switchgear is used for distribution at department or zone level in industrial and service sector environments.
- **With multiple boxes**  
Each box, usually of the protected type and with release flanges, contains a functional unit which can be an automatic circuit-breaker, a starter, or a socket complete with circuit-breaker lock or protection.

### 3.3 Installation conditions

From the viewpoint of the installation conditions, the switchgear is distinguished by:

- **Switchgear for indoor use**  
Switchgear intended to be used in rooms where there are normal operating conditions for indoor use, as specified in 6.1 of IEC 60439-1, i.e.:

#### Environmental installation conditions for indoor use

Relative humidity	Air temperature	Altitude
0% (at a maximum temperature of 40° C)	Maximum temperature ≤40° C	Not above 2000 m
90% (at a maximum temperature of 20° C)	Maximum average temperature over a period of 24 hours ≤35° C	
	Minimum temperature ≥ -5° C	

- **Switchgear for outdoors**  
Switchgear intended for use under normal operating conditions for outdoor installations, as specified in 6.1 of IEC 60439-1, i.e.:

#### Environmental installation for outdoor conditions

Relative humidity	Air temperature	Altitude
100% temporarily (at a maximum temperature of 25° C)	Maximum temperature ≤40° C	Not above 2000 m
	Maximum average temperature over a period of 24 hours ≤35° C	
	Minimum temperature ≥-25° C for temperate climates	
	Minimum temperature ≥-50° C for arctic climates	

- **Fixed switchgear**  
Switchgear intended to be fixed on the installation site, for example on the floor or on a wall and to be used in that place.
- **Moveable switchgear**  
Switchgear intended to be easily moved from one place of use to another.



## ▶ 3 Classification of electric switchgear

3.4 Functional classification

### 3.4 Functional classification

In relation the functions it is intended for, the switchgear can be divided into the following types:

- **Main distribution switchboards**  
The main distribution switchboards are usually installed immediately to the load side of the MV/LV transformers or the generators. The main distribution switchboards include one or more incoming units, any bus ties and a relatively small number of outgoing units. They are also called Power Centers (PC).
- **Secondary distribution switchboards**  
The secondary distribution switchboards include a vast category of switchboards destined for power distribution and are usually fitted with an incoming unit and numerous outgoing units.
- **Motor control and switchgear**  
The motor control and switchgear is intended for centralised control and protection of motors: it therefore includes the relative coordinated switching and protection equipment as well as the control and signalling auxiliaries. It is also called Motor control center (MCC).
- **Control, measurement and protection switchgear**  
The control, measurement and protection switchgear generally consists of banks which mainly contain equipment intended to operate, control and measure industrial plants and processes.
- **On-board machine switchgear**  
The on-board machine switchgear is functionally similar to the previous ones. It has the task of allowing machine interfacing with the electric power source and with the operator.
- **Switchgear for construction sites**  
The switchgear for construction sites has various sizes, which go from a simple plug socket unit to true distribution switchboards in a metal housing or in insulating material. It is generally of the mobile or, in any case, transportable type.

## 4 IP degree of protection in switchgear

The IP degree of protection indicates the level of protection of the housing against access to dangerous parts, entry of solid foreign bodies and penetration of water.

The IP code is the identification system for the degrees of protection, in accordance with what is prescribed by the IEC 60529 Standard.

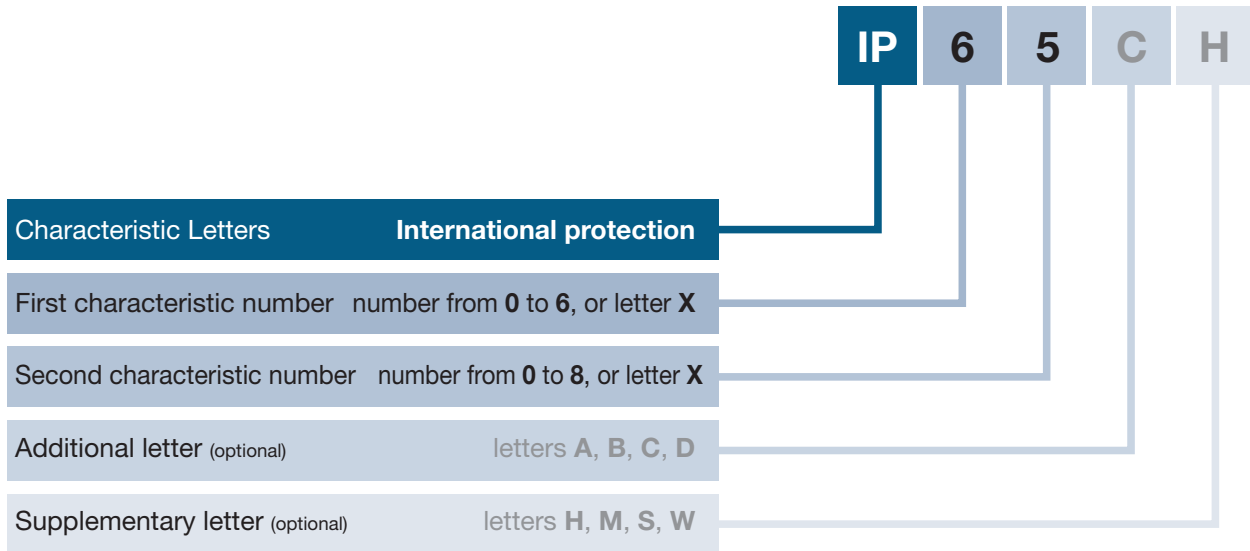

We now also indicate the meaning of the different numbers and letters in detail:

	Protection of the equipment	Against access to dangerous parts with:
First characteristic number (entry of foreign solid bodies)	<b>0</b> unprotected	unprotected
	<b>1</b> $\geq 50$ mm of diameter	back of hand
	<b>2</b> $\geq 12,5$ mm of diameter	finger
	<b>3</b> $\geq 2,5$ mm of diameter	tool
	<b>4</b> $\geq 1$ mm of diameter	wire
	<b>5</b> protected against dust	wire
Second characteristic number (penetration of water)	<b>6</b> totally protected against dust	wire
	<b>0</b> unprotected	
	<b>1</b> falling vertically	
	<b>2</b> falling drops of water (15° angle)	
	<b>3</b> rain	
	<b>4</b> water spray	
	<b>5</b> jets of water	
	<b>6</b> powerful jets (similar to sea waves)	
Additional letter (optional)	<b>7</b> temporary immersion	
	<b>8</b> continuous immersion	
	<b>A</b>	back of hand
	<b>B</b>	finger
Supplementary letter (optional)	<b>C</b>	tool
	<b>D</b>	wire
	<b>H</b> High voltage equipment	
	<b>M</b> Test using water with equipment in motion	
	<b>S</b> Test using water with equipment in motion	
	<b>W</b> Atmospheric conditions	

The additional letter indicates the degree of protection for people against access to dangerous parts.

The additional letters are only used:

- if the actual protection against access to dangerous parts is higher than the one indicated by the first characteristic number;
- or if only protection against access to dangerous parts is indicated, the first characteristic number is then replaced by an X.

This higher protection could be provided, for example, by barriers, by openings of suitable shape or by internal distances of the dangerous parts away from the housing.

## ▶ 4 IP degree of protection in ArTu switchgear

4.1 Grado di protezione IP nei quadri ArTu

### 4.1 IP degree of protection in ArTu switchgear

With regard to the switchgear, where not otherwise specified by the manufacturer, the degree of protection is valid for the whole switchgear, mounted and installed as in ordinary use (with door closed). The manufacturer can also indicate the degrees of protection relative to special configurations which may be present in service, such as the degree of protection with doors open and the one with apparatus removed or racked out.

For closed switchgear the Standard requires at least IP degree of protection 2X or IPXXB.

Below are the degrees of protection which can be obtained with ABB SACE ArTu switchgear.

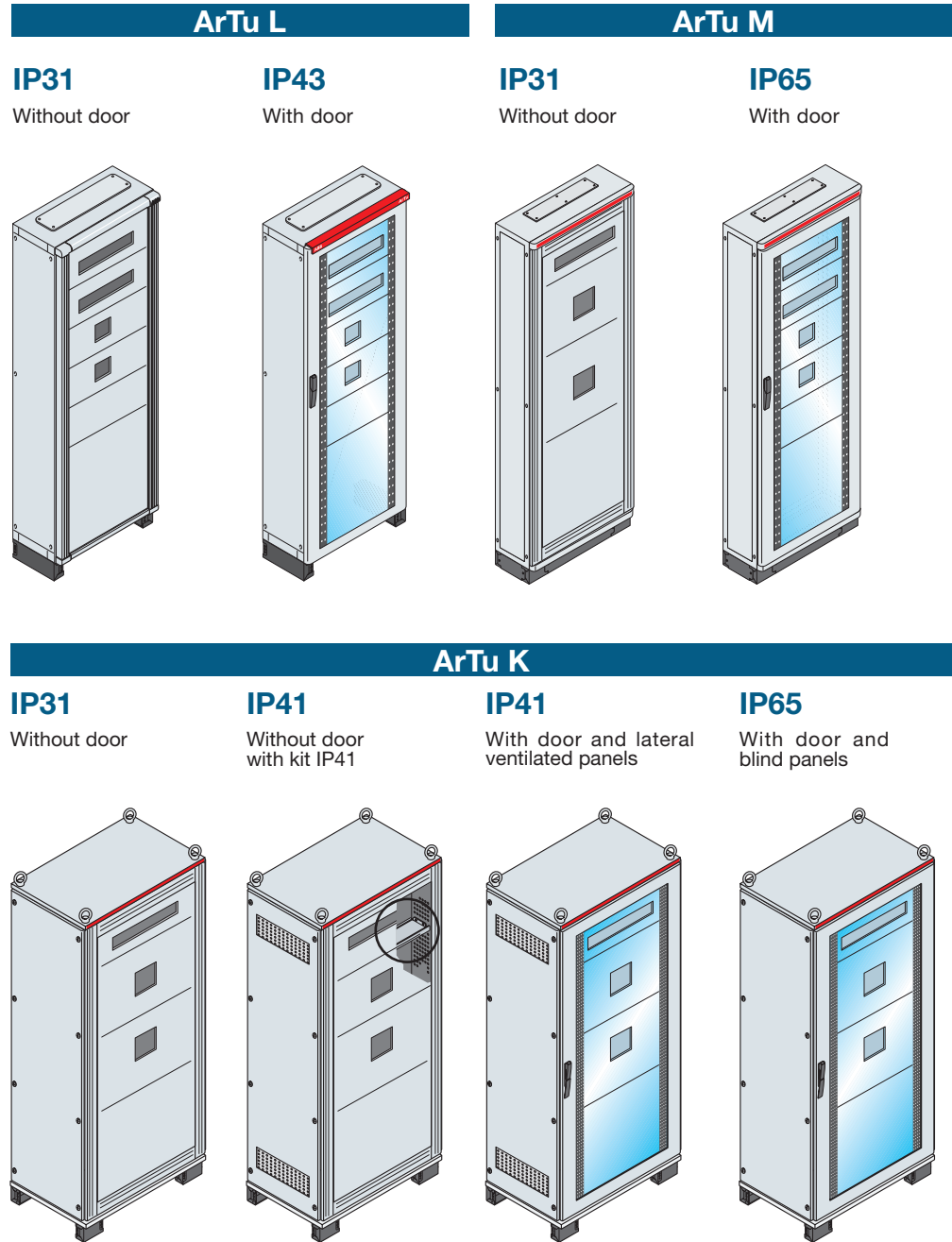

## 4 IP degree of protection in ArTu switchgear

4.2 IP degree of protection and installation environment

### 4.2 IP degree of protection and installation environment

At present there is no Standard which relates the IP degree of protection to the environment in which the switchgear is inserted, except for special environments with risk of explosion.

As an indication, this table taken from the UTE C 15-103 guide is shown, which relates the environments and the degrees of protection of ABB SACE ArTu switchgear.



*It must be remembered that the ABB SACE ArTu switchgear is switchgear for indoor use.*

Industrial factories	IP31-41	IP43	IP65	Industrial factories	IP31-41	IP43	IP65
accumulators (fabrication)		•		metal engraving		•	
acids (fabrication and storage)		•		wool (carding of)			•
alcoholic liquids (storage)		•		dairies			•
alcohol (fabrication and storage)		•		laundries		•	•
aluminium (fabrication and storage)			•	public wash-houses			•
animals (breeding)			•	wood (working of)			•
asphalt bitumen (storage)			•	halogen liquids (use)	•		
breweries			•	flammable liquids (storage and use)	•		
lime (furnaces)			•	spirits (fabrication)	•		
coal (warehouses)				machines (machine rooms)	•		
fuels (fabrication and storage)			•	butchers			•
paper (storage)	•			magnesium			
paper (fabrication)		•	•	(fabrication, processing and storage)	•		
paper (preparation of paste)			•	plastic materials (fabrication)			•
cardboard (fabrication)		•		slaughter houses			•
bottling lines			•	bricks (factory for )			•
tar (treatment)		•		metals (treatment of metals)		•	
quarries			•	thermal motors (tests)	•		
cellulose (fabrication of objects)	•			ammunitions (deposits)		•	
cellulose (fabrication)			•	nickel (treatment of the minerals)		•	
cement works			•	oil (extraction)	•		
chlorine (fabrication and storage)		•		leather (fabrication and storage)	•		
coking plants			•	furs (scutching)			•
glues (fabrication)		•		paint (fabrication and storage)		•	
combustible liquids (stores)		•		powder factory			•
tanneries			•	chemicals (fabrication)	•		•
fertilizers (fabrication and storage)			•	perfumes (fabrication and storage)	•		
chromium plating (factories for)		•		oil refineries			•
pickling			•	copper (treatment of the minerals)	•		
detergents (fabrication)			•	rubbish (treatment)			•
distilleries		•		welds		•	
electrolysis		•		cured meat factories			•
explosives (fabrication and storage)			•	soaps (fabrication)	•		
joinery			•	sawmills			•
ironmongery (fabrication)	•			silk and hair (preparation)			•
iron (fabrication and treatment)			•	grain or sugar silos			•
spinning mills			•	soda (fabrication and storage)		•	
cheese-making			•	fabrics (fabrication)			•
gas (factories and storage)	•			dyeing factories			•
gypsum (fabrication and storage)			•	printing works	•		
foam rubber				paints (fabrication and use)		•	
(fabrication, transformation)			•	clothes (deposits)	•		
cereals (factories and storage)			•	glassworks		•	
fats (treatment of fatty bodies)			•	zinc (zinc processing)	•		
hydrocarbons (extraction)		•	•	sulphur (treatment)			•
inks (fabrication)	•			sugar refineries			•

GENERAL STANDARDS AND CHARACTERISTICS

VERIFYING THE OVERTEMPERATURES

PROTECTION AGAINST SHORT-CIRCUIT AND ELECTRIC SHOCKS

PRACTICAL INDICATIONS CERTIFICATION AND CONSTRUCTION

CERTIFICATES

DECLARATION OF CONFORMITY

## ▶ 4 IP degree of protection and heating

4.3 IP degree of protection and heating

### **4.3 IP degree of protection and heating**

The degree of protection of switchgear affects the capacity of getting rid of heat: the higher the degree of protection is, the less the switchgear manages to get rid of heat. For this reason it is advisable to use a degree of protection suitable for the installation environment.

For example, using ArTu K switchgear with door and ventilated side panels, a degree of protection of IP41 is guaranteed, whereas if blind side panels are used, the degree becomes IP65.

Both pieces of switchgear guarantee inaccessibility to circuit-breakers through the front door, however switchgear with ventilated side panels allows better ventilation than switchgear with blind side panels. It is therefore preferable to use the former where the installation environment allows this.

## 5 Degrees of IK protection of the housings

### 5.1 IK degree of protection of ArTu switchgear

The IK degree indicates the level of protection provided by the housing for the equipment against harmful mechanical impacts, and is checked using standardised test methods.

The IK code is the coding system for indicating the degree of protection provided by housings against harmful mechanical impacts, in accordance with what is prescribed in the EN 50102 Standard.

The degree of protection of the housing against impacts is indicated by the IK code in the following way:



Each characteristic numerical group represents an impact energy value as indicated in the table:

#### Relationship between the IK degree of protection and impact energy

Code IK	IK00	IK01	IK02	IK03	IK04	IK05	IK06	IK07	IK08	IK09	IK10
Joule impact energy	(*)	0,14	0,2	0,35	0,5	0,7	1	2	5	10	20

(\*) Unprotected according to the following Standard.

The degree of protection is normally applied to the complete housing. If parts of the housing have different degrees of protection, the latter must be indicated separately.

#### 5.1 IK degree of protection of ArTu switchgear

With regard to ArTu switchgear, the degree of IK protection is valid for the whole switchgear, mounted and installed as in ordinary use (with door closed).

The degrees of protection against external mechanical impacts (IK code) of the ArTu series of switchgear are given below.

<b>IK 08</b>		<p><b>ArTu L</b></p> <p>Impact energy in Joule <b>5,00</b></p>
<b>IK 09</b> With glazed door		<p><b>ArTu M - K</b></p> <p>Impact energy in Joule <b>10,00</b></p>
<b>IK 10</b> With blind door		<p><b>ArTu M - K</b></p> <p>Impact energy in Joule <b>20,00</b></p>

## 6 Forms of segregation

By form of segregation, the type of division foreseen inside the switchgear is intended. Segregation by means of barriers or partitions (metal or insulating) can have the purpose of:

- ensuring protection against direct contacts (at least IPXXB), in the case of access to a part of the switchgear cut off from the power supply, in relation to the rest of the switchgear which remains supplied with power
- reducing the probability of striking and propagation of an internal arc
- preventing passage of solid bodies between different parts of the switchgear (at least IP2X degree of protection).

By partition, the separating element between two compartments is intended, whereas the barrier protects the operator from direct contacts and from the effects of the breaking apparatus arc in the normal direction of access.

The following table given in the IEC 60439-1 Standard highlights the typical forms of segregation which can be obtained by using barriers or partitions:

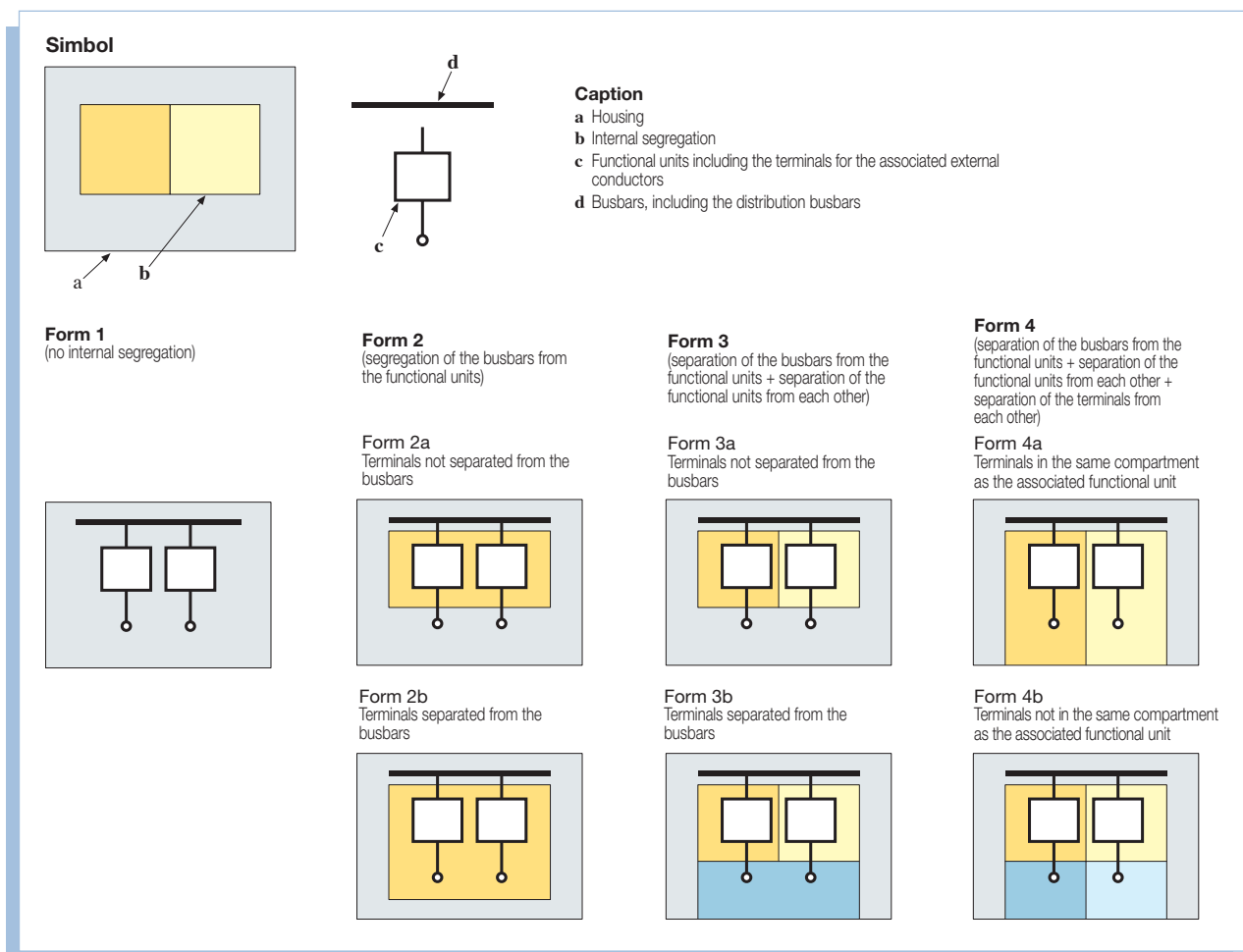

By means of a kit, the ABB SACE ArTu K switchgear can make the following forms of segregation:

- form 1** no segregation
- form 2** covers form 2a and form 3a of the Standard
- form 3** covers form 3b of the Standard
- form 4** covers form 4b of the Standard

## 7 Checking the overtemperature limits inside ArTu switchgear

7.1 Introduction

### 7.1 Introduction

Checking the overtemperature limits set by the IEC 60439-1 Standard can be carried out by means of a laboratory test or by means of extrapolation, starting from experimental data. The IEC 60439-1 Standard sets the overtemperature limits which must not be exceeded when the heating test is carried out. These overtemperatures are applied considering an ambient temperature which must not exceed +40 °C and its average value must not exceed +35 °C over a reference period of 24 hours.

Switchgear parts	Overtemperature
Type of incorporated components: switchgear and controlgear, electronic sub-assemblies ( <i>rectifier bridges, printed circuits</i> ), parts of equipment ( <i>e.g. regulator, stabilized power feeder, operational amplifier</i> ).	<sup>(1)</sup> In accordance with the standards relative to individual components, or, when there are no such standards, according to the manufacturer's instructions, taking into consideration the internal temperature of the equipment.
External terminals for insulated conductors	70 K
Busbars and conductors, coupling contacts of removable or withdrawable parts which are connected to the busbars	Limited by: <ul style="list-style-type: none"> <li>· mechanical resistance of the conductor material;</li> <li>· possible influence on the adjacent equipment;</li> <li>· admissible temperature limit for the insulating materials in contact with the conductor;</li> <li>· influence of the conductor temperature on the apparatus connected to it;</li> <li>· type and surface treatment of the contact material (for coupling contacts).</li> </ul>
Manual operating mechanism parts:	Made of metal 15 K Made of insulating material 25 K <i>For the manual operating mechanism parts located inside the switchgear, only accessible after its opening (e.g. emergency racking-out handles for infrequent use), higher overtemperatures are permitted.</i>
Accessible housing and external covers	Metal surfaces 30 K Insulating surfaces 40 K Unless otherwise indicated, in the case of covers and housings which are accessible but do not have to be touched under normal service conditions, the overtemperature limits can be increased by 10 K
Special connection of the plug socket and plug type	Determined by the limits fixed for the equipment components they are part of

<sup>(1)</sup> With regard to circuit-breakers, the overtemperature limits are as follows:

**70 K** if an insulated conductor is connected to the terminal.

**85 K** for ABB circuit-breaker terminals if insulated conductors are not connected directly to these (the 85 K overtemperature always refers to an ambient temperature outside switchgear of 35°C).



## 7 Checking the overtemperature limits inside ArTu switchgear

7.2 Thermal checking and certification of ABB SACE ArTu switchgear

### 7.2 Thermal checking and certification of ABB SACE ArTu switchgear

The aim of this document is to provide manufacturers who use ABB SACE ArTu structures with an aid which allows the overtemperatures inside the switchgear to be checked.

To do this, it was decided to publish part of the test reports relating to the switchgear heating tests.

#### From the point of view of switchgear certification it is possible to:

Certify the switchgear as **TTA** when there are the following two conditions:

- among the configurations indicated in paragraph 7.4 there is a similar one which, compared with the switchgear to be constructed, has variants (or deviations) which do not change the performances in a crucial way
- as indicated in paragraph 7.3, the Pr total power dissipated by the switchgear to be constructed is less than the Pp total power dissipated by the tested switchgear.

Certify the switchgear as **PTTA** when the following two conditions exist

- among the configurations indicated in paragraph 7.4 there is a similar one which, compared with the switchgear to be constructed, has variants (or deviations) which do not change the performances in a crucial way
- the Pr total power dissipated by the switchgear to be constructed is higher than the Pp total power dissipated by the tested switchgear, but verification of the overtemperature illustrated in paragraph 7.3 leads to a **positive result**.

Certify the switchgear as **PTTA** when there are the following two conditions

- there is not a similar one among the configurations indicated in paragraph 7.4.
- the calculation of the total power dissipated by the apparatus, compared with the power which can be dissipated by the structure (distribution switchgear general Catalogue), leads to an overtemperature which is acceptable for the electric circuits and devices inside the switchgear, operating at the normal service current.

The method recommended in this document is based on calculation of the air overtemperature inside the switchgear taken from IEC 60890.

This Standard specifies that the method of calculation is only applicable if the following conditions are satisfied:

- the dissipated power inside the housing is on the whole distributed uniformly;
- the switchgear installed is arranged so as not to obstruct air circulation, except in a minor way;
- the switchgear installed is foreseen for DC or AC up to 60 Hz inclusive, with the sum of the currents in the power supply circuits not exceeding 3150 A;
- the conductors which carry high currents and the structural parts are arranged so that losses due to eddy currents are negligible;
- for housings with ventilation openings, the cross-section of the air outlet openings is at least 1.1 times the cross-section of the inlet openings;
- there are not more than three horizontal partitions in the ANS or in any of its cubicles;
- should the housings with external ventilation openings be divided into compartments, the surface of the ventilation openings in each internal horizontal partition must be at least 50% of the horizontal cross-section of the compartment.

## 7 Checking the overtemperature limits inside ArTu switchgear

7.2 Thermal checking and certification of ABB SACE ArTu switchgear

In applications with segregated switchgear not all of these hypotheses are satisfactory. It was decided in any case to use this calculation method since:

- the method, also valid for switchgear in insulating material, is conservative in the case of metal structures
- the recommended check is not based only on the overtemperature value obtained by means of the calculation. The method of calculation for IEC 60890 is, in fact, only used for a comparison between two similar configurations.

### Certification and checking overtemperature limits

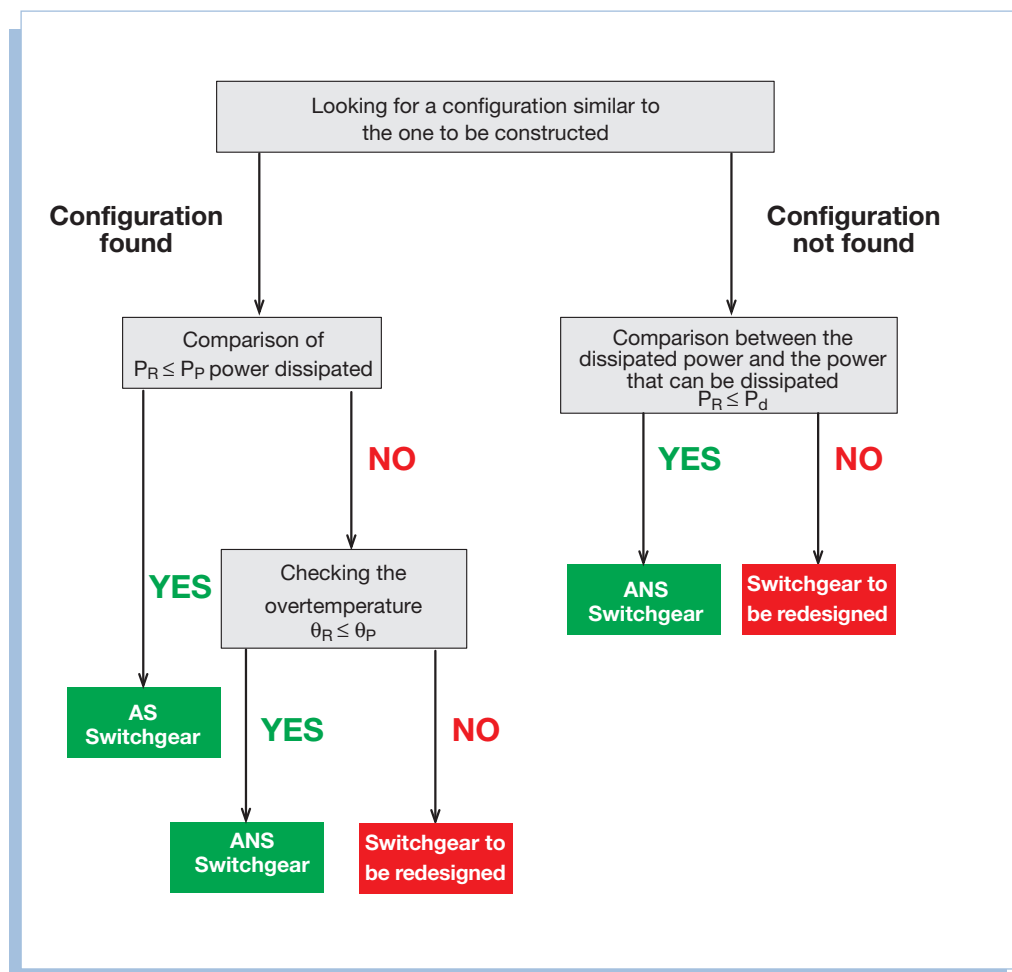

## 7 Checking the overtemperature limits inside ArTu switchgear

7.3 Checking procedure

### 7.3 Checking procedure

#### Selection of a piece of tested switchgear similar to the switchgear to be constructed

First of all, the switchgear most similar to the one to be designed must be selected among the configurations shown.

This similarity must be found in: the dimensions of the switchgear, type and number of pieces of equipment, degree of protection, form of segregation, value of the currents in the different pieces of apparatus during the test, and methods of installation (exposed, wall-mounted, covered on one side..).

The following differences are obviously acceptable:

- lower degree of protection and form of segregation than the switchgear to be constructed compared with the tested switchgear;
- larger linear dimensions of the switchgear to be constructed compared with the tested switchgear;
- number of pieces of equipment inside the switchgear to be constructed less than the number of pieces of equipment inside the tested switchgear;
- method of installation which allows better dispersion of heat by the switchgear to be constructed compared with the one tested.

Below, we give the different methods of installation considered in the IEC 60890 Standard

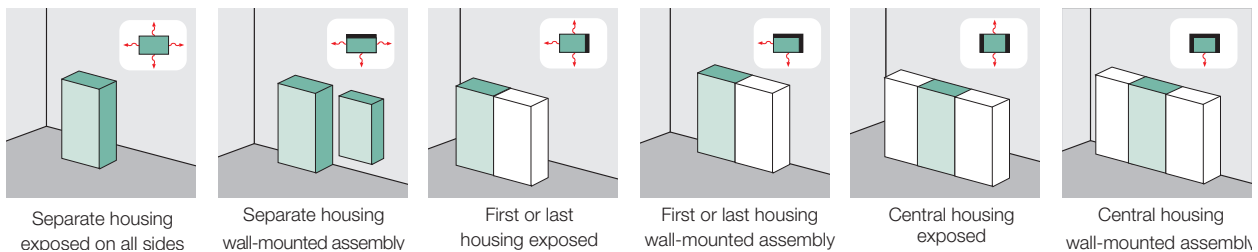

Once the most suitable tested configuration for the study has been selected, a comparison between the power dissipated by the switchgear to be constructed ( $P_r$ ) and the power dissipated by the tested switchgear ( $P_p$ ) must be made.

(For calculation of the power that can be dissipated, see the following paragraphs)

If it is found that:

$$P_r \leq P_p$$

the switchgear to be constructed can be considered to conform (TTA)

If, on the other hand:

$$P_r > P_p$$

you must pass on to calculation of the air overtemperature inside the switchgear.

#### Calculation of the powers dissipated inside the switchgear

To be able to make a comparison of the dissipated powers, the calculation method must be identical for both pieces of switchgear.

Calculation of the dissipated powers indicated in the configurations presented is done taking into account the actual powers dissipated by the various components:

#### Circuit-breakers

Given the powers dissipated at the rated current ( $I_n$ ), indicated on the following page, and the current which actually passes through the circuit-breakers ( $I_b$ ) the power effectively dissipated by the apparatus can be calculated:

$$P(I_b) = P(I_n) \left( \frac{I_b}{I_n} \right)^2$$

The values established in this way must be increased by a factor which depends on the type of circuit-breaker. This coefficient is used to take the connections which carry current to the circuit-breakers into account.

Type of circuit-breaker	Large moulded-case (S7-S8)	Moulded-case	Modular
Coefficient of increase (C)	1,3	1,5	2

## 7 Checking the overtemperature limits inside ArTu switchgear

7.3 Checking procedure

Power loss Tmax moulded-case circuit-breakers

Total (3/4 poles) power loss [W]	In [A]	T11P		T1		T2		T3		T4		T5		T6		T7 S,H,L		T7 V	
		F	F	F	P	F	P	F	P/W	F	P/W	F	W	F	W	F	W	F	W
<b>Releases</b>	1			4.5	5.1														
	1.6			6.3	7.5														
	2			7.5	8.7														
	2.5			7.8	9														
	3.2			8.7	10.2														
	4			7.8	9														
	5			8.7	10.5														
	6.3			10.5	12.3														
	8			8.1	9.6														
	10			9.3	10.8														
	12.5			3.3	3.9														
	16	1.5	4.5	4.2	4.8														
	20	1.8	5.4	5.1	6				10.8	10.8									
	25	2	6	6.9	8.4														
	32	2.1	6.3	8.1	9.6				11.1	11.1									
	40	2.6	7.8	11.7	13.8														
	50	3.7	11.1	12.9	15				11.7	12.3									
	63	4.3	12.9	15.3	18	12.9	15.3												
	80	4.8	14.4	18.3	21.6	14.4	17.4	13.8	15										
	100	7	21	25.5	30	16.8	20.4	15.6	17.4										
	125	10.7	32.1	36	44.1	19.8	23.7	18.6	21.6										
	160	15	45	51	60	23.7	28.5	22.2	27										
	200					39.6	47.4	29.7	37.2										
	250					53.4	64.2	41.1	52.8										
	320									40.8	62.7								
	400									58.5	93								
500									86.4	110.1									
630											92	117							
800											93	119							
<b>PR221 PR222 PR223</b>	10			1.5	1.8														
	25			3	3.6														
	63			10.5	12														
	100			24	27.2			5.1	6.9										
	160			51	60			13.2	18										
	250							32.1	43.8										
	320							52.8	72	31.8	53.7								
	400									49.5	84			15	27	24	36		
	630									123	160.8	90	115	36	66	60	90		
	800											96	125	57,9	105,9	96	144		
	1000											150		90	165	150	225		
	1250													141	258	234,9	351,9		
1600													231	423					

F: fixed W: withdrawable P: plug-in

Power loss air circuit-breakers Emax

Total (3/4 poles) power loss [W]	X1B-N		X1L		E1B-N		E2B-N-S		E2L		E3N-S-H-V		E3L		E4S-H-V	
	F	W	F	W	F	W	F	W	F	W	F	W	F	W	F	W
In=630	41	63	50	87												
In=800	65	100	80	140	65	95	29	53			22	36				
In=1000	102	157	125	219	96	147	45	83			38	58				
In=1250	159	257	196	342	150	230	70	130	105	165	60	90				
In=1600	260	400			253	378	115	215	170	265	85	150				
In=2000							180	330			130	225	215	330		
In=2500											205	350	335	515		
In=3200											330	570			235	425
In=4000															360	660

F: fixed W: withdrawable

The values indicated in the tables refer to balanced loads, with phase currents of In, and are valid for both three-pole and four-pole circuit-breakers and for switch-disconnectors. For the latter, the current in the neutral is nil.

## 7 Checking the overtemperature limits inside ArTu switchgear

7.3 Checking procedure

### Distribution busbars

The busbars present in the column being examined must be considered in the dissipated power calculation.

The length can be calculated approximately by inspecting the front of the switchgear.

The power dissipated by the busbars can be determined by means of the following relation:

$$P(I_b) = P(I_n) \left( \frac{I_b}{I_n} \right)^2 \cdot L_{\text{piece}} \cdot 3$$

Where:

$P(I_n)$  is the dissipated power per unit of length at the rated current and its value can be taken from table B.2 of the IEC 60890 Standard given below, or from the manufacturer's catalogues.

$(L_{\text{piece}} \cdot 3)$  is the length of the piece of busbar which passes through the column being examined, multiplied by 3 as it is a three-phase circuit.

Table B.2 of the IEC 60890 Standard was used for the calculations in this document, considering an air temperature of 55°C around the busbar.

### Operating current and dissipated powers of the bare busbars, with vertical layout, without direct connections to the apparatus

Length x thickness	Cross- section (Cu)	Maximum admissible conductor temperature: 85 °C															
		Air temperature around the conductors inside the housing: 35 °C								Air temperature around the conductors inside the housing: 55 °C							
		from 50 Hz at 60 Hz AC				DC and AC up to 16 2/3 Hz				from 50 Hz at 60 Hz AC				DC and AC up to 16 2/3 Hz			
		operating current	dissipated powers (1)	operating current	dissipated powers (1)	operating current	dissipated powers (1)	operating current	dissipated powers (1)	operating current	dissipated powers (1)	operating current	dissipated powers (1)	operating current	dissipated powers (1)	operating current	dissipated powers (1)
mm x mm	mm <sup>2</sup>	A*	W/m	A**	W/m	A*	W/m	A**	W/m	A*	W/m	A**	W/m	A*	W/m	A**	W/m
12 x 2	23,5	144	19,5	242	27,5	144	19,5	242	27,5	105	10,4	177	14,7	105	10,4	177	14,7
15 x 2	29,5	170	21,7	282	29,9	170	21,7	282	29,9	124	11,6	206	16,0	124	11,6	206	16,0
15 x 3	44,5	215	23,1	375	35,2	215	23,1	375	35,2	157	12,3	274	18,8	157	12,3	274	18,8
20 x 2	39,5	215	26,1	351	34,8	215	26,1	354	35,4	157	13,9	256	18,5	157	12,3	258	18,8
20 x 3	59,5	271	27,6	463	40,2	271	27,6	463	40,2	198	14,7	338	21,4	198	14,7	338	21,4
20 x 5	99,1	364	29,9	665	49,8	364	29,9	668	50,3	266	16,0	485	26,5	266	16,0	487	26,7
20 x 10	199	568	36,9	1097	69,2	569	36,7	1107	69,6	414	19,6	800	36,8	415	19,5	807	37,0
25 x 5	124	435	34,1	779	55,4	435	34,1	78	55,6	317	18,1	568	29,5	317	18,1	572	29,5
30 x 5	149	504	38,4	894	60,6	505	38,2	899	60,7	368	20,5	652	32,3	369	20,4	656	32,3
30 x 10	299	762	44,4	1410	77,9	770	44,8	1436	77,8	556	27,7	1028	41,4	562	23,9	1048	41,5
40 x 5	199	641	47,0	1112	72,5	644	47,0	1128	72,3	468	25,0	811	38,5	469	24,9	816	38,5
40 x 10	399	951	52,7	1716	88,9	968	52,6	1796	90,5	694	28,1	1251	47,3	706	28,0	1310	48,1
50 x 5	249	775	55,7	1322	82,9	782	55,4	1357	83,4	566	29,7	964	44,1	570	29,4	989	44,3
50 x 10	499	1133	60,9	2008	102,9	1164	61,4	2141	103,8	826	32,3	1465	54,8	849	32,7	1562	55,3
60 x 5	299	915	64,1	1530	94,2	926	64,7	1583	94,6	667	34,1	1116	50,1	675	34,4	1154	50,3
60 x 10	599	1310	68,5	2288	116,2	1357	69,5	2487	117,8	955	36,4	1668	62,0	989	36,9	1814	62,7
80 x 5	399	1170	80,7	1929	116,4	1200	80,8	2035	116,1	858	42,9	1407	61,9	875	42,9	1484	61,8
80 x 10	799	1649	85,0	2806	138,7	1742	85,1	3165	140,4	1203	45,3	2047	73,8	1271	45,3	1756	74,8
100 x 5	499	1436	100,1	2301	137,0	1476	98,7	2407	121,2	1048	53,3	1678	72,9	1077	52,5	1756	69,8
100 x 10	999	1982	101,7	3298	164,2	2128	102,6	3844	169,9	1445	54,0	2406	84,4	1552	54,6	2803	90,4
120 x 10	1200	2314	115,5	3804	187,3	2514	115,9	4509	189,9	1688	61,5	2774	99,6	1833	61,6	3288	101,0

\* one conductor per phase

\*\* two conductors per phase

(1) single length

## 7 Checking the overtemperature limits inside ArTu switchgear

7.3 Checking procedure

### Incoming and outgoing switchgear cables

The power dissipated by the pieces of cable which enter the switchgear must be counted separately.

In some cases, the variability in length of these pieces causes their power to be negligible, whereas in others it is decisive for correct calculation of the dissipated power inside the switchgear.

The power dissipated by them can be calculated by means of the following relation:

$$P(I_b) = P(I_n) \left( \frac{I_b}{I_n} \right)^2 \cdot L_{\text{piece}} \cdot 3$$

Where:

$P(I_n)$  is the dissipated power per unit of length at the rated current and its value can be taken from table B1 of the IEC 60890 Standard given below, or from the manufacturer's catalogues.

$(L_{\text{piece}} \cdot 3)$  is the length of the piece of cable inside the switchgear or of the column being examined, multiplied by 3 as it is a three-phase circuit. This length can be calculated approximately by inspecting the front of the switchgear.

Table B1 of the IEC 60890 Standard was used for the calculations in this document, considering an air temperature of 55°C around the cable.

### Operating current and dissipated powers of the insulated conductors

Cross-section (Cu)	Maximum admissible temperature of the conductor: 70 °C											
	Air temperature around the conductors inside the housing											
	35 °C		55 °C		35 °C		55 °C		35 °C		55 °C	
	operating current	dissipated powers (2)	operating current	dissipated powers (2)	operating current	dissipated powers (2)	operating current	dissipated powers (2)	operating current	dissipated powers (2)	operating current	dissipated powers (2)
mm <sup>2</sup>	A	W/m	A	W/m	A	W/m	A	W/m	A	W/m	A	W/m
1,5	12	2,1	8	0,9	12	2,1	8	0,9	12	2,1	8	0,9
2,5	17	2,5	11	1,1	20	3,5	12	1,3	20	3,5	12	1,3
4	22	2,6	14	1,1	25	3,4	18	1,8	25	3,4	20	2,2
6	28	2,8	18	1,2	32	3,7	23	1,9	32	3,7	25	2,3
10	38	3,0	25	1,3	48	4,8	31	2,0	50	5,2	32	2,1
16	52	3,7	34	1,6	64	5,6	42	2,4	65	5,8	50	3,4
25					85	6,3	55	2,6	85	6,3	65	3,7
35					104	7,5	67	3,1	115	7,9	85	5,0
50					130	7,9	85	3,4	150	10,5	115	6,2
70					161	8,4	105	3,6	175	9,9	149	7,2
95					192	8,7	125	3,7	225	11,9	175	7,2
120					226	9,6	147	4,1	250	11,7	210	8,3
150					275	11,7	167	4,3	275	11,7	239	8,8
185					295	10,9	191	4,6	350	15,4	273	9,4
240					347	12,0	225	5,0	400	15,9	322	10,3
300					400	13,2	260	5,6	460	17,5	371	11,4

(1) Each desired layout, with the specific values, refers to a group of conductors gathered together in a bundle (six conductors loaded at 100%)

(2) Single length

## 7 Checking the overtemperature limits inside ArTu switchgear

7.3 Checking procedure

### Calculation of the overtemperature

The value of the overtemperature inside the switchgear can be calculated by means of ABB SACE software tools such as DMBWin or DOCWin.

The parameters required by the software are as follows:

- linear dimensions of the switchgear (height, length, width)
- methods of installation (exposed separate, separate wall-mounted, ..)
- air inlet area

*(the Standard prescribes an air outlet area at least equal to 1.1 times the inlet one, otherwise the inlet area must be reduced by 10 % in relation to the actual one)*

- ambient temperature
- number of horizontal segregations
- total dissipated power

Using the same method or tool, the following is calculated:

- the air temperature at mid height and at the top of the switchgear to be constructed ( $\theta_R$ );
- the air temperature at mid height and at the top of the tested switchgear ( $\theta_P$ ).

If:

both at the top and at mid height, then the switchgear to be constructed conforms (ANS);

$$\theta_R \leq \theta_P$$

$\theta_R \geq \theta_P$  or at the top or at mid height, then the switchgear to be constructed cannot be considered to conform and redesigning it must be considered.

In the extracts from test certificates, in point 7.4, both the temperatures calculated with DMBWin and the temperatures measured during the test are given. The latter must not be used for the comparison.

### N. B.

To obtain an air temperature the same as or lower than the tested switchgear starting at the same or higher power than the switchgear to be constructed, where this is compatible with design limitations, one can:

- use a structure with larger linear dimensions
- position the switchgear in an air-conditioned environmental with average ambient temperature lower than 35°C
- use an installation method which allows greater ventilation of the switchgear
- use a device for forced ventilation of the switchgear.

These parameters can be inserted in the overtemperature calculation in order to calculate the overtemperature inside the switchgear to be tested.

On the other hand, the different degrees of protection, and even less the different forms of segregation cannot be taken into account to obtain lower overtemperatures.

## 7 Checking the overtemperature limits inside ArTu switchgear

7.4 Extracts from test certificates

### 7.4 Extracts from test certificates

The following pages give a series of results obtained during the heating tests.

Each page contains:

- a schematic drawing of the front of the switchgear with the busbar path
- details of the busbars passing through (length, cross-section, current and dissipated power)
- details of the circuit-breakers (model, size, current, dissipated power, terminals and version)
- details of the cables (length, cross-section, current and dissipated power)
- air temperatures measured during the test.
- air temperatures calculated using the ABB DMBWin software.

#### N. B.

There are mainly the Isomax series of moulded-case circuit-breakers in the test certificates given here. From the thermal point of view, switchgear to be constructed with Tmax series of circuit-breakers can be considered equivalent to switchgear tested with Isomax series of circuit-breakers of the same size and rated current.

Thermal equivalence:

- S1 → T1
- S2 → T2
- S3 → T3
- S4 → T4
- S5 → T5

Obviously, the dissipated powers to be used in the calculation of  $P_r$  (dissipated power of the switchgear to be constructed) will be those of the circuit-breakers actually used..



## 7 Checking the overtemperature limits inside ArTu switchgear

7.4 Extracts from test certificates

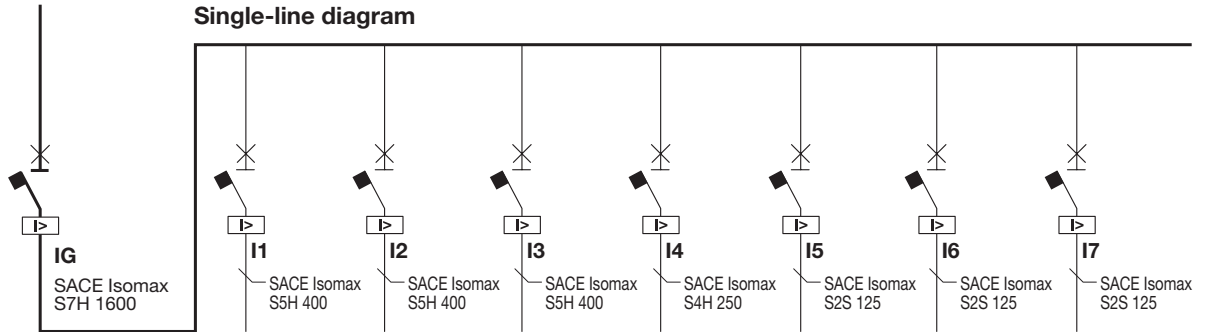

**Front of switchgear**

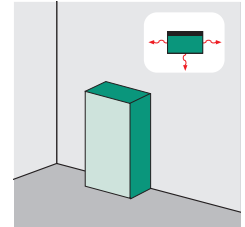
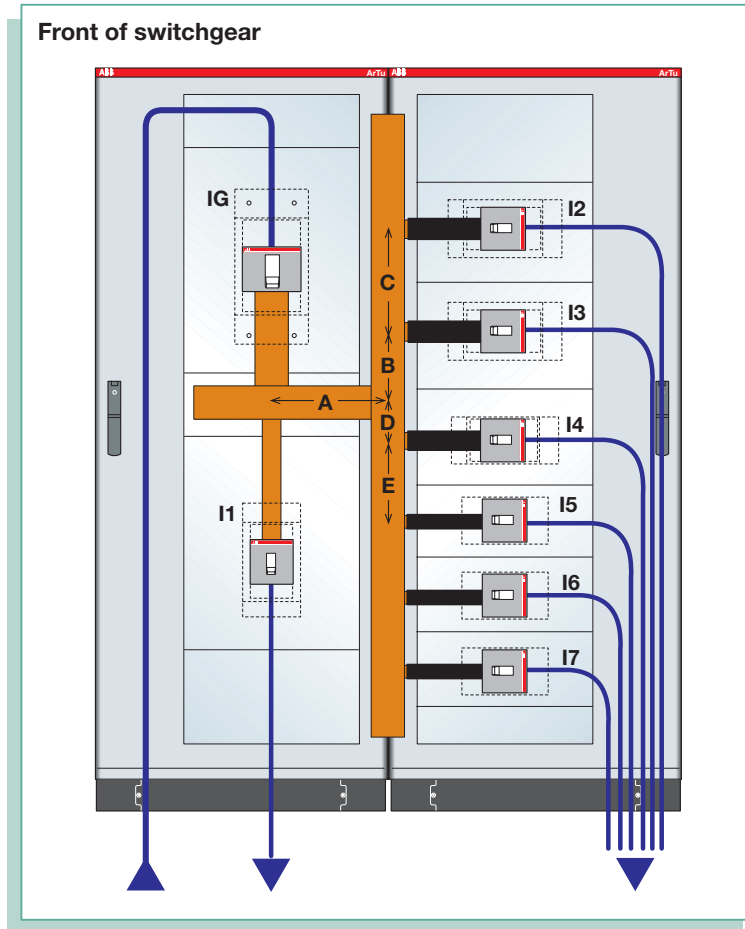

## 7 Checking the overtemperature limits inside ArTu switchgear

7.4 Extracts from test certificates

Circuit-breaker	Type	Terminals	In[A]	Ib[A]	P(Ib) [W]	P(Ib)xC [W]
IG	S7H1600 (F)	Rear	1600	1200	146,3	(x1,3)=190,1
I1	S5H 400 (F)	Rear	400	320	41,6	(x1,5)=62,4
I2	S5H 400 (F)	Rear	400	300	36,6	(x1,5)=54,8
I3	S5H 400 (F)	Rear	400	300	36,6	(x1,5)=54,8
I4	S4H 250 (F)	Rear	250	220	31	(x1,5)=46,5
I5	S2S 125 (F)	Rear	125	60	5,5	(x1,5)=8,3
I6	S2S 125 (F)	Rear	125	0	0	0
I7	S2S 125 (F)	Rear	125	0	0	0
<b>Total power dissipated by the circuit-breakers</b>						<b>417</b>

Busbar	Cross-section [mm]x[mm]	Length [mm]	Current Ib	P(Ib) [W]
A	100x10	300	880	18
B	100x10	200	600	5,6
C	100x10	300	300	2,1
D	100x10	100	280	0,6
E	100x10	250	60	0,1
<b>Total power dissipated by the busbars</b>				<b>26</b>

Cable	Cross-section [mm <sup>2</sup> ]	Length [mm]	Current Ib[A]	P(Ib) [W]
IG	3x240	2400	1200	341,3
I1	185	500	320	19,4
I2	185	2100	300	71,5
I3	185	1800	300	61,3
I4	120	1500	220	41,3
I5	35	1100	60	8,2
<b>Total power dissipated by the busbars</b>				<b>543</b>

Dissipated powers				Dimensions [mm]			0 horiz. segreg.	Temperatures obtained °C		
Busb.	Apparatus	Cables	Tot.	H	L	D		Heights	DMB	Exp.
26	417	543	<b>986</b>	2000	1900	800	Exposed separate	2 m	54	53
								1 m	47	46
								Ambient	24	24

Versions:  
F = Fixed  
E = Withdrawable

Test N° 1	
Structure	<b>ArTu K</b>
Segregation	<b>Not segregated</b>
Degree of protection	<b>IP65</b>
Assembly	<b>Wall-mounted separate</b>

GENERAL STANDARDS AND CHARACTERISTICS

VERIFYING THE OVERTEMPÉRATURES

PROTECTION AGAINST SHORT-CIRCUIT AND ELECTRIC SHOCKS

PRACTICAL INDICATIONS AND CERTIFICATION AND CONSTRUCTION

CERTIFICATES

DECLARATION OF CONFORMITY

## 7 Checking the overtemperature limits inside ArTu switchgear

7.4 Extracts from test certificates

Single-line diagram

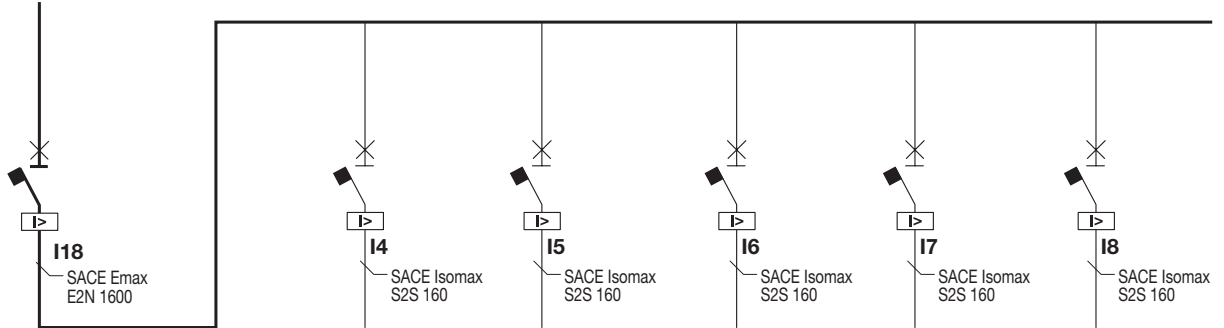

Front of switchgear

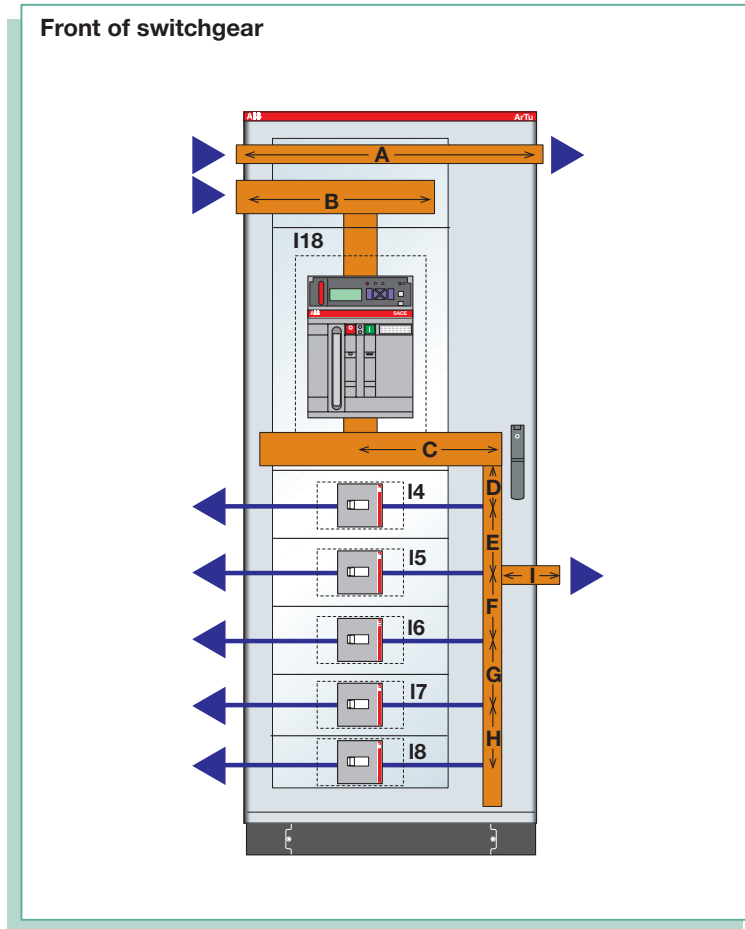

## 7 Checking the overtemperature limits inside ArTu switchgear

7.4 Extracts from test certificates

Circuit-breaker	Type	Terminals	In[A]	Ib[A]	P(Ib) [W]	P(Ib)xC [W]
I18	E2N1600 (E)	Horizontal	1600	1214	123,8	(x1,3)=160,9
I4	S2S 160 (F)	Rear	160	50	2,9	(x1,5)=4,4
I5	S2S 160 (F)	Rear	160	50	2,9	(x1,5)=4,4
I6	S2S 160 (F)	Rear	160	50	2,9	(x1,5)=4,4
I7	S2S 160 (F)	Rear	160	50	2,9	(x1,5)=4,4
I8	S2S 160 (F)	Rear	160	50	2,9	(x1,5)=4,4
<b>Total power dissipated by the circuit-breakers</b>						<b>183</b>

Busbar	Cross-section [mm]x[mm]	Length [mm]	Current Ib	P(Ib) [W]
A	80x10	950	800	57,1
B	3x(60x10)	360	1214	21,2
C	3x(60x10)	480	1214	28,2
D	80x10	100	1214	13,8
E	80x10	200	1164	25,5
F	80x10	200	150	negligible
G	80x10	200	100	negligible
H	80x10	200	50	negligible
I	80x10	70	964	6,1
<b>Total power dissipated by the busbars</b>				<b>152</b>

Dissipated powers				Dimensions [mm]			3 horiz. segreg.	Temperatures obtained °C		
Busb.	Apparatus	Cables	Tot.	H	L	D		Heights	DMB	Exp.
152	183	0	<b>335</b>	2000	950	1000	Exposed separate	At top	48	46
								Middle	43	34
								Air	24	24

Versions:  
F = Fixed  
E = Withdrawable

Test N° 2	
Structure	<b>ArTu K</b>
Segregation	<b>Form 3a</b>
Degree of protection	<b>IP65</b>
Assembly	<b>Central housing exposed</b>

GENERAL STANDARDS AND CHARACTERISTICS

VERIFYING THE OVERTEMPÉRATURES

PROTECTION AGAINST SHORT-CIRCUIT AND ELECTRIC SHOCKS

PRACTICAL INDICATIONS AND CERTIFICATION AND CONSTRUCTION

CERTIFICATES

DECLARATION OF CONFORMITY

## 7 Checking the overtemperature limits inside ArTu switchgear

7.4 Extracts from test certificates

Single-line diagram

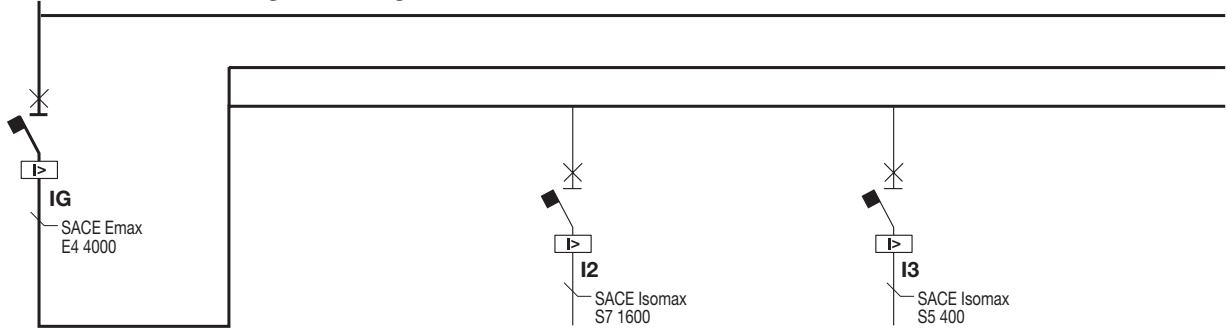

Front of switchgear

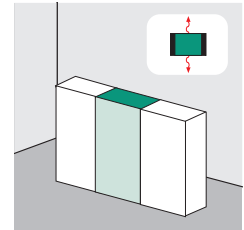
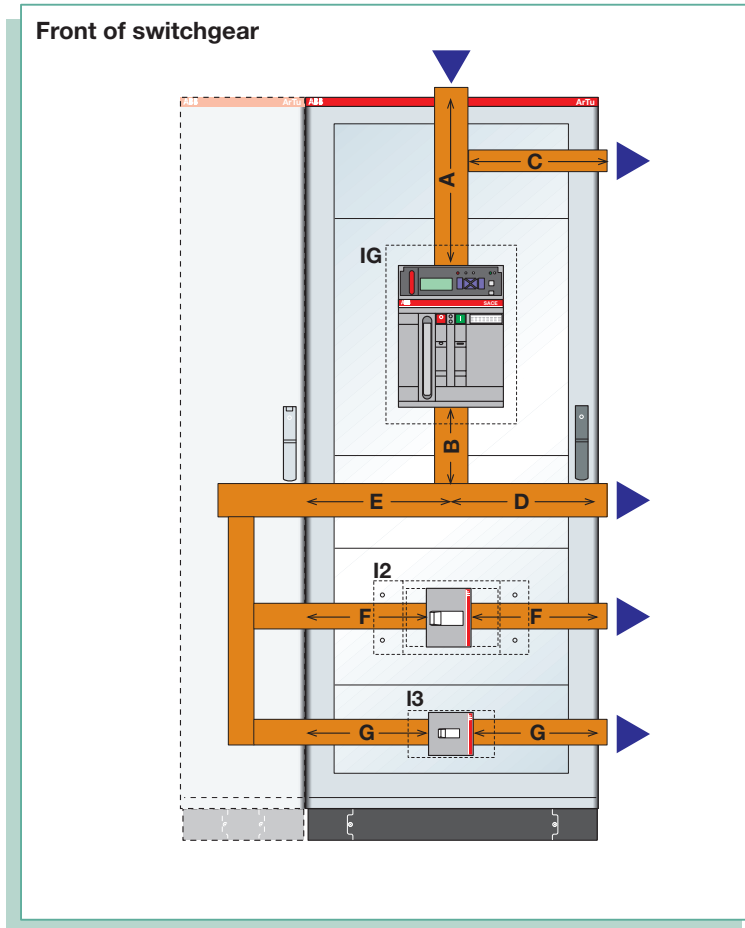

## 7 Checking the overtemperature limits inside ArTu switchgear

7.4 Extracts from test certificates

Circuit-breaker	Type	Terminals	In[A]	Ib[A]	P(Ib) [W]	P(Ib)xC [W]
IG	E4 4000 (E)	Horizontal	4000	3200	422,4	(x1,3)=549,1
I2	S7 1600 (F)	Rear	1600	266	7,2	(x1,3)=9,3
I3	S5 400 (F)	Rear	400	120	5,9	(x1,5)=8,8
<b>Total power dissipated by the circuit-breakers</b>						<b>567</b>

Busbar	Cross-section [mm]x[mm]	Length [mm]	Current Ib	P(Ib) [W]
C	80x10	460	800	27,6
D	3x(200x10)	460	1214	8,8
E	3x(200x10)	460	1986	23,5
<b>Total power dissipated by the busbars</b>				<b>60</b>

Dissipated powers				Dimensions [mm]			3 horiz. segreg.	Temperatures obtained °C		
Busb.	Apparatus	Cables	Tot.	H	L	D		Heights	DMB	Exp.
60	567	-	<b>627</b>	2000	950	1000	Exposed separate	At top	64	61
								Middle	55	49
								Air	24	24

Versions:  
F = Fixed  
E = Withdrawable

Test N° 3	
Structure	ArTu K
Segregation	Form 3a
Degree of protection	IP65
Assembly	Central housing exposed

## 7 Checking the overtemperature limits inside ArTu switchgear

7.4 Extracts from test certificates

Single-line diagram

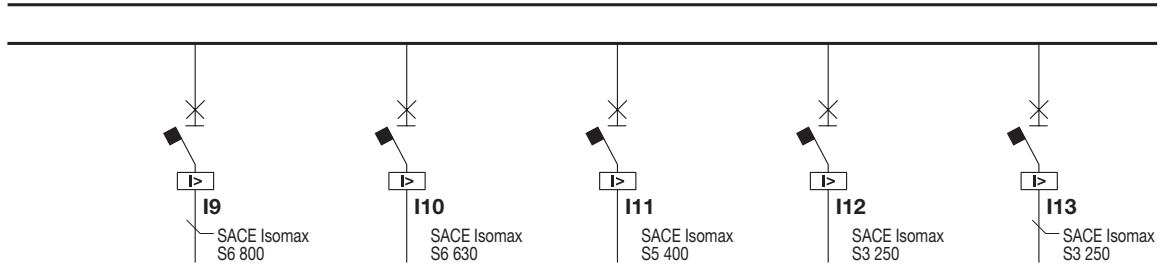

Front of switchgear

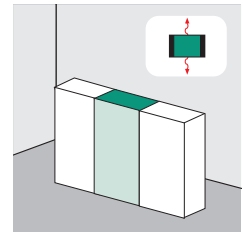
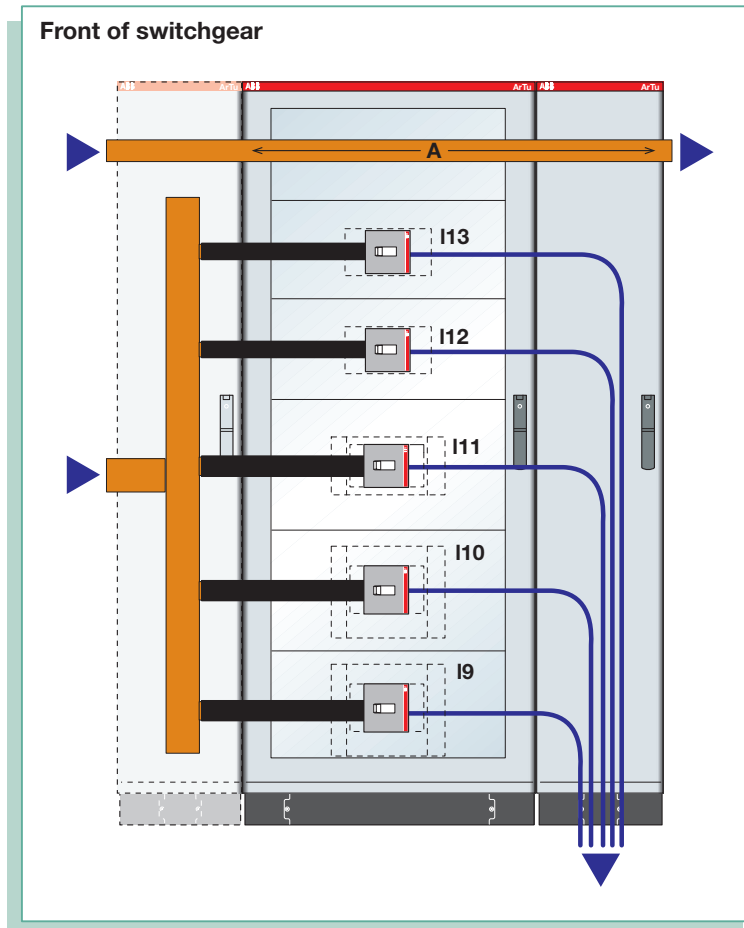

## 7 Checking the overtemperature limits inside ArTu switchgear

7.4 Extracts from test certificates

Circuit-breaker	Type	Terminals	In[A]	Ib[A]	P(Ib) [W]	P(Ib)xC [W]
I9	S6 800 (F)	Rear	800	320	14,9	(x1,5)=22,3
I10	S6 630 (F)	Rear	630	252	14,7	(x1,5)=22,1
I11	S5 400 (F)	Rear	400	160	10,4	(x1,5)=15,6
I12	S3 250 (F)	Rear	250	100	8	(x1,5)=12
I13	S3 250 (F)	Rear	250	100	8	(x1,5)=12
<b>Total power dissipated by the circuit-breakers</b>						<b>84</b>

Busbar	Cross-section [mm] x [mm]	Length [mm]	Current Ib	P (Ib) [W]
A	80x10	1040	800	62,5
<b>Total power dissipated by the busbars</b>				<b>63</b>

Cable	Cross-section [mm <sup>2</sup> ]	Length [mm]	Current Ib[A]	P(Ib) [W]
I9	185	500	320	19,4
I10	150	900	252	26,4
I11	70	1300	160	32,6
I12	35	1600	100	33,1
I13	35	1900	100	39,5
<b>Total power dissipated by the cables</b>				<b>151</b>

Dissipated powers				Dimensions [mm]			3 horiz. segreg.	Temperatures obtained °C		
Busb.	Apparatus	Cables	Tot.	H	L	D		Heights	DMB	Exp.
63	87	151	<b>301</b>	2000	1100	1000	Covered on 2 sides	At top	44	44
								Middle	40	39
								Air	24	24

Versions:  
F = Fixed  
E = Withdrawable

Test N° 4	
Structure	<b>ArTu K</b>
Segregation	<b>Form 3a</b>
Degree of protection	<b>IP65</b>
Assembly	<b>Central housing exposed</b>

GENERAL STANDARDS AND CHARACTERISTICS

VERIFYING THE OVERTEMPÉRATURES

PROTECTION AGAINST SHORT-CIRCUIT AND ELECTRIC SHOCKS

PRACTICAL INDICATIONS AND CERTIFICATION AND CONSTRUCTION

CERTIFICATES

DECLARATION OF CONFORMITY



## 7 Checking the overtemperature limits inside ArTu switchgear

7.4 Extracts from test certificates

GENERAL STANDARDS AND CHARACTERISTICS

VERIFYING THE OVERTEMPATURES

PROTECTION AGAINST SHORT-CIRCUIT AND ELECTRIC SHOCKS

PRACTICAL INDICATIONS CERTIFICATION AND CONSTRUCTION

CERTIFICATES

DECLARATION OF CONFORMITY

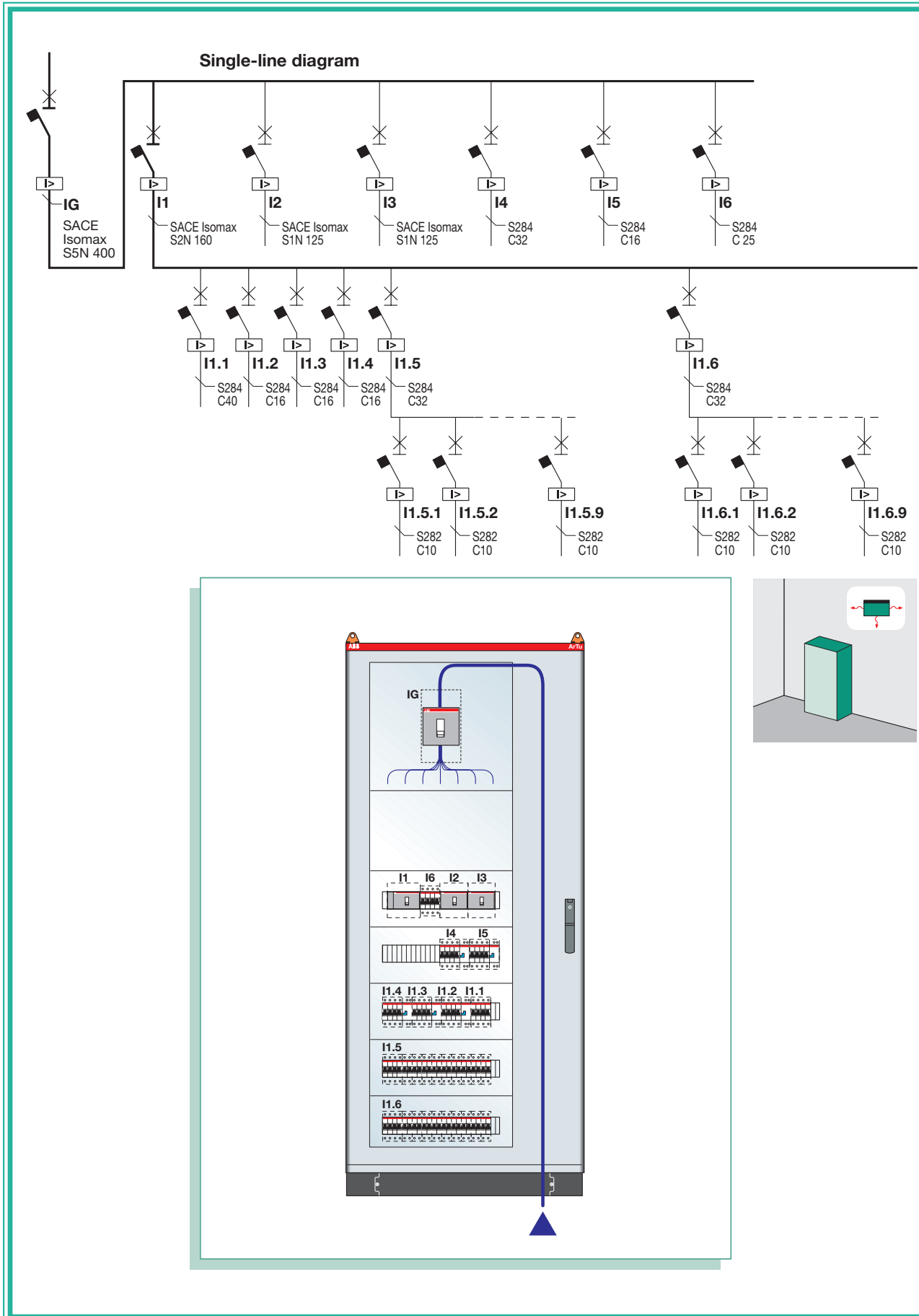

## 7 Checking the overtemperature limits inside ArTu switchgear

7.4 Extracts from test certificates

Circuit-breaker	Type	Terminals	In [A]	Ib [A]	P (Ib) [W]	P (Ib) x C [W]
IG	S5N400 (F)	Front	400	340	43,4	(x1,5)=65
I2	S1N125 (F)	Front	125	88	9,9	(x1,5)=14,9
I3	S1N125 (F)	Front	125	88	9,9	(x1,5)=14,9
I4	S284 C32+DDA 64/40		32	23	5,7+1,8	(x2)=15
I5	S284 C16+DDA 64/25		16	11	3,3+0,6	(x2)=7,8
I6	S284 C25		25	18	3	(x2)=6
I1	S2N 160 (F)	Front	160	112	14,7	(x1,5)=22
I1.1	S284 C40 (F)		40	28	7,1	(x2)=14,2
I1.2	S284 C16+DDA 64/25		16	11	3,3+0,6	(x2)=7,8
I1.3	S284 C16+DDA 64/25		16	11	3,3+0,6	(x2)=7,8
I1.4	S284 C16+DDA 64/25		16	11	3,3+0,6	(x2)=7,8
I1.5	S284 C32		32	27	7,9	(x2)=15,8
I1.5.1 ÷ I1.5.9	S282 C10		10	9	2,2	(x2)(x9)=39,6
I1.6	S284 C32		32	27	7,9	(x2)=15,8
I1.6.1 ÷ I1.6.9	S282 C10		10	9	2,2	(x2)(x9)=39,6
<b>Total power dissipated by the circuit-breakers</b>						<b>294</b>

Cable	Cross-section [mm <sup>2</sup> ]	Length [mm]	Current Ib[A]	P(Ib) [W]
IG	240	2300	340	79,2
I2	25	1100	88	22
I3	25	1100	88	22
I4	4	900	23	8
I5	1,5	900	11	4,6
I6	2,5	1100	18	10
I1.1	4	700	28	9,7
I1.2	1,5	1000	11	5,1
I1.3	1,5	1000	11	5,1
I1.4	1,5	700	11	3,6
I1.5.1-I1.5.9	1,5	600	9	1,4(x9)=12,6
I1.6.1-1.6.9	1,5	400	9	0,9(x9)=8,2
<b>Total power dissipated by the cables</b>				<b>190</b>

Dissipated powers				Dimensions [mm]			3 horiz. segreg.	Temperatures obtained °C		
Busb.	Apparatus	Cables	Tot.	H	L	D		Heights	DMB	Exp.
0	190	294	<b>484</b>	2000	950	250	Wall mounted separate	At top	70	66
								Middle	54	49
								Air	26	26

Versions:  
F = Fixed  
E = Withdrawable

Test N° 5	
Structure	ArTu K
Segregation	Form 3a
Degree of protection	IP65
Assembly	Wall-mounted separate

GENERAL STANDARDS AND CHARACTERISTICS

VERIFYING THE OVERTEMPÉRATURES

PROTECTION AGAINST SHORT-CIRCUIT AND ELECTRIC SHOCKS

PRACTICAL INDICATIONS AND CERTIFICATION AND CONSTRUCTION

CERTIFICATES

DECLARATION OF CONFORMITY

## 7 Checking the overtemperature limits inside ArTu switchgear

7.4 Extracts from test certificates

GENERAL STANDARDS AND CHARACTERISTICS

VERIFYING THE OVERTEMPURURES

PROTECTION AGAINST SHORT-CIRCUIT AND ELECTRIC SHOCKS

PRACTICAL INDICATIONS CERTIFICATION AND CONSTRUCTION

CERTIFICATES

DECLARATION OF CONFORMITY

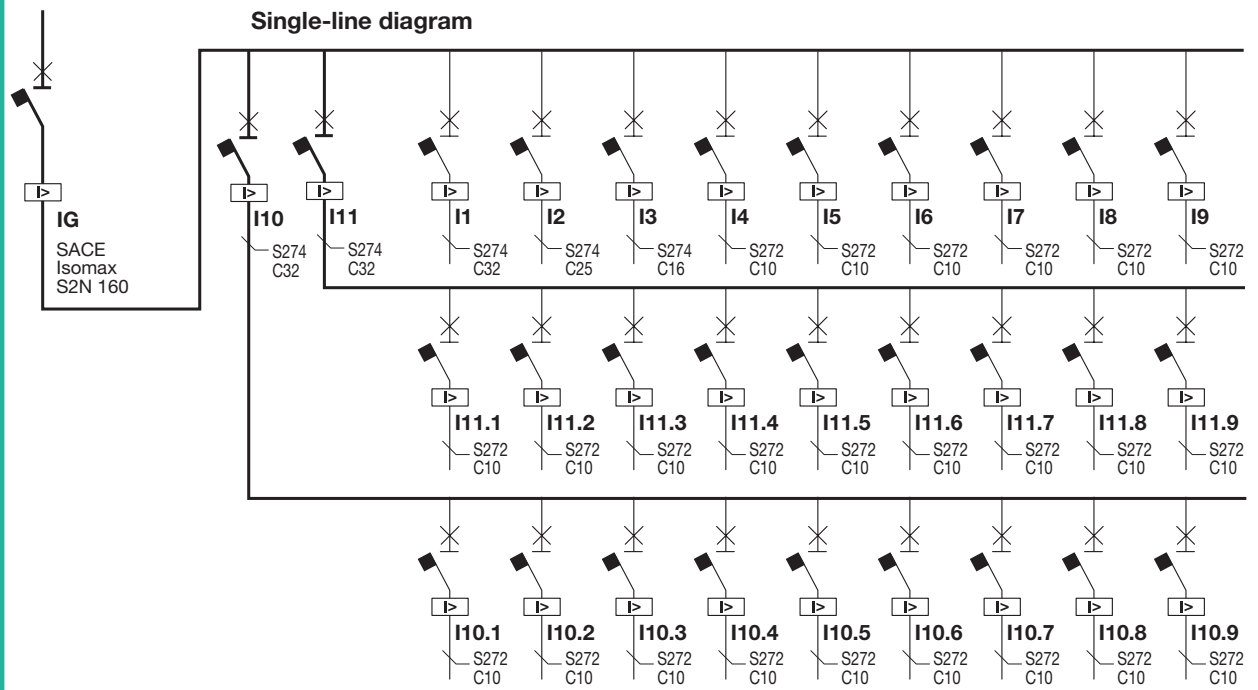

**Front of switchgear**

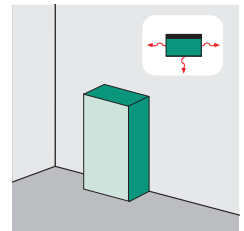
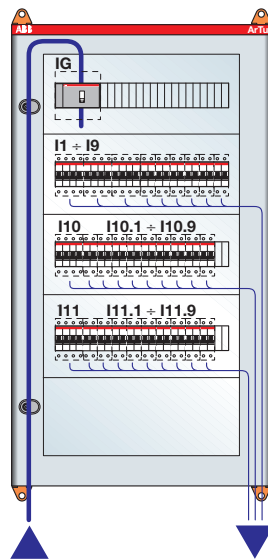

## 7 Checking the overtemperature limits inside ArTu switchgear

7.4 Extracts from test certificates

Circuit-breaker	Type	Terminals	In [A]	Ib [A]	P (Ib) [W]	P (Ib) x C [W]
IG	S2N160 (F)	FRONT	160	125	18,3	(x1,5)=27,5
I1	S274 C32		32	25	6,8	(x2)=13,6
I2	S274 C25		25	20	3,6	(x2)=7,2
I3	S274 C16		16	13	4,6	(x2)=9,2
I4	S272 C10		10	8	0,9	(x2)=1,8
I5	S272 C10		10	8	0,9	(x2)=1,8
I6	S272 C10		10	8	0,9	(x2)=1,8
I7	S272 C10		10	8	0,9	(x2)=1,8
I8	S272 C10		10	8	0,9	(x2)=1,8
I9	S272 C10		10	8	0,9	(x2)=1,8
I10	S274 C32		32	25	6,8	(x2)=13,6
I10.1-10.9	S272 C10		10	8	0,9	(x2)(x9)=16,2
I11	S274 C32		32	25	6,8	(x2)=13,6
I11.1-11.9	S272 C10		10	8	0,9	(x2)(x9)=16,2
<b>Total power dissipated by the circuit-breakers</b>						<b>128</b>

Cable	Cross-section [mm <sup>2</sup> ]	Length [mm]	Current Ib[A]	P(Ib) [W]
IG	50	1100	125	24,3
I1	4	650	25	6,8
I2	2,5	650	20	7,1
I3	1,5	650	13	4,6
I4	1,5	650	8	1,2
I5	1,5	650	8	1,2
I6	1,5	650	8	1,2
I7	1,5	650	8	1,2
I8	1,5	650	8	1,2
I9	1,5	650	8	1,2
I10.1-10.9	1,5	450	9x8	9x0,8=7,2
I11.1-11.9	1,5	250	9x8	9x0,5=4,5
<b>Total power dissipated by the cables</b>				<b>62</b>

Dissipated powers				Dimensions [mm]			0 horiz. segreg.	Temperatures obtained °C		
Busb.	Apparatus	Cables	Tot.	H	L	D		Heights	DMB	Exp.
0	128	62	<b>190</b>	1000	700	200	Wall mounted separate	At top	65	63
								Middle	51	51
								Air	22	22

Versions:  
F = Fixed  
E = Withdrawable

Test N° 6	
Structure	ArTu K
Segregation	Form 3a
Degree of protection	IP65
Assembly	Wall-mounted separate

GENERAL STANDARDS AND CHARACTERISTICS

VERIFYING THE OVERTEMPÉRATURES

PROTECTION AGAINST SHORT-CIRCUIT AND ELECTRIC SHOCKS

PRACTICAL INDICATIONS AND CERTIFICATION AND CONSTRUCTION

CERTIFICATES

DECLARATION OF CONFORMITY

## 7 Checking the overtemperature limits inside ArTu switchgear

7.4 Extracts from test certificates

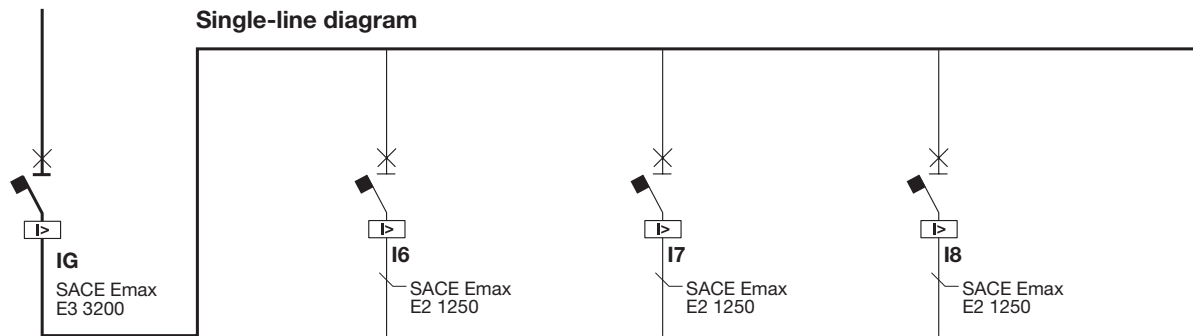

**Front of switchgear**

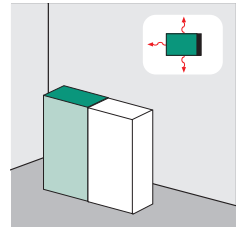
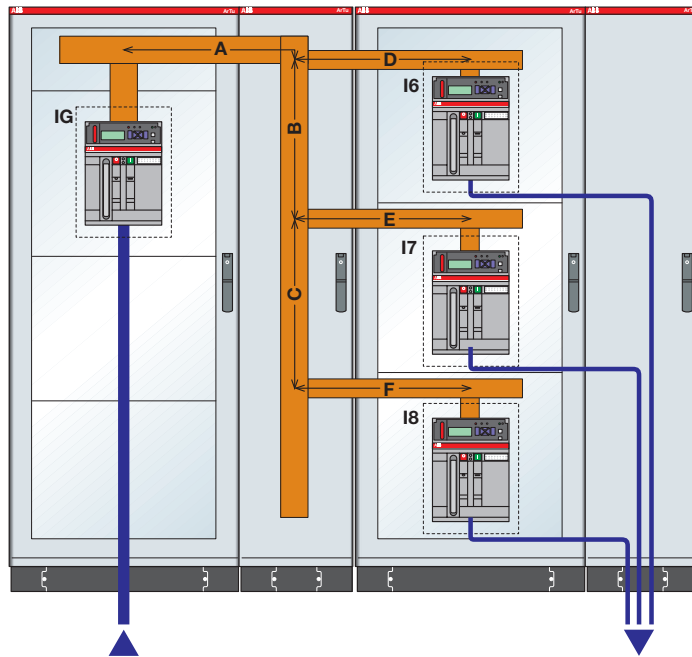

## 7 Checking the overtemperature limits inside ArTu switchgear

7.4 Extracts from test certificates

Circuit-breaker	Type	Terminals	In [A]	Ib [A]	P (Ib) [W]	P (Ib) x C [W]
IG	E3 3200 (F)	Verticali	3200	2820	256,3	(x1,3)=333,2
I6	E2 1250 (F)	Horizontal	1250	940	39,6	(x1,3)=51,5
I7	E2 1250 (F)	Horizontal	1250	940	39,6	(x1,3)=51,5
I8	E2 1250 (F)	Horizontal	1250	940	39,6	(x1,3)=51,5
<b>Total power dissipated by the circuit-breakers</b>						<b>488</b>

Busbar	Cross-section [mm] x [mm]	Length [mm]	Current Ib	P (Ib) [W]
A	3x100x10	600	2820	123,4
B	3x100x10	600	1880	54,9
C	3x100x10	600	940	13,7
D	120x10	360	940	20,6
E	120x10	360	940	20,6
<b>Total power dissipated by the busbars</b>				<b>254</b>

Cable	Cross-section [mm <sup>2</sup> ]	Length [mm]	Current Ib[A]	P(Ib) [W]
IG	7x300	1000	2820	282,3
I6	2x300	1700	940	186,6
I7	2x300	1200	940	131,7
<b>Total power dissipated by the cables</b>				<b>601</b>

Dissipated powers				Dimensions [mm]			0 horiz. segreg.	Temperatures obtained °C		
Busb.	Apparatus	Cables	Tot.	H	L	D		Heights	DMB	Exp.
254	488	601	<b>1345</b>	2000	2200	800	Covered on one side	At top	64	64
								Middle	56	54
								Air	30	30

Versions:  
F = Fixed  
E = Withdrawable

Test N° 7	
Structure	<b>ArTu K</b>
Segregation	<b>Not segregated</b>
Degree of protection	<b>IP65</b>
Assembly	<b>Exposed covered on one side</b>

GENERAL STANDARDS AND CHARACTERISTICS

VERIFYING THE OVERTEMPURURES

PROTECTION AGAINST SHORT-CIRCUIT AND ELECTRIC SHOCKS

PRACTICAL INDICATIONS CERTIFICATION AND CONSTRUCTION

CERTIFICATES

DECLARATION OF CONFORMITY

## 7 Checking the overtemperature limits inside ArTu switchgear

7.4 Extracts from test certificates

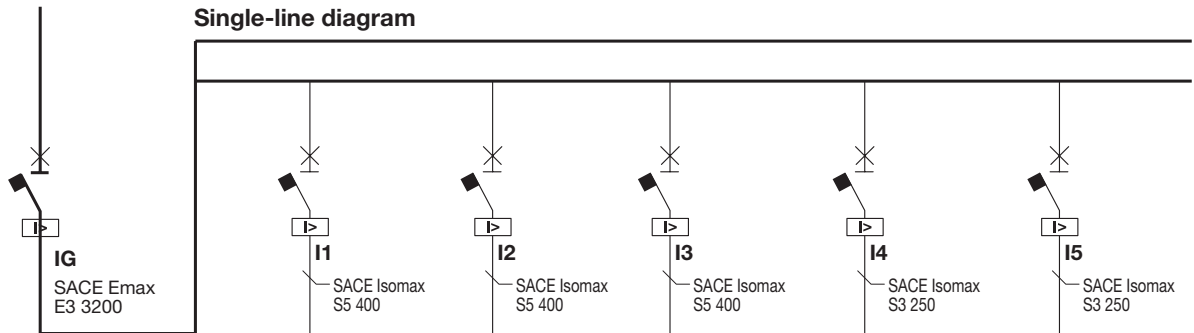

**Front of switchgear**

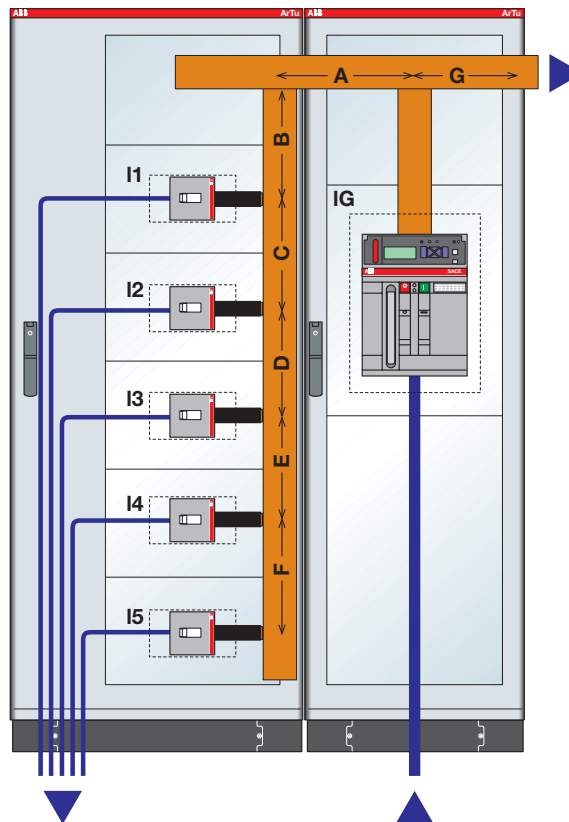

## 7 Checking the overtemperature limits inside ArTu switchgear

7.4 Extracts from test certificates

Circuit-breaker	Type	Terminals	In [A]	Ib [A]	P (Ib) [W]	P (Ib) x C [W]
IG	E3 3200 (F)	Vertical	3200	2820	256,3	(x1,3)=333,2
I1	S5 400 (F)	Rear	400	380	58,7	(x1,5)=88
I2	S5 400 (F)	Rear	400	380	58,7	(x1,5)=88
I3	S5 400 (F)	Rear	400	380	58,7	(x1,5)=88
I4	S3 250 (F)	Rear	250	230	42,3	(x1,5)=63,5
I5	S3 250 (F)	Rear	250	230	42,3	(x1,5)=63,5

**Total power dissipated by the circuit-breakers** **724**

Busbar	Cross-section [mm] x [mm]	Length [mm]	Current Ib	P (Ib) [W]
A	3x100x10	360	1600	23,8
B	80x10	300	1600	72,1
C	80x10	300	1220	41,9
D	80x10	300	840	19,9
E	80x10	300	460	6
F	80x10	300	230	1,5
G	3x100x10	360	1220	13,9

**Total power dissipated by the busbars** **179**

Cable	Cross-section [mm <sup>2</sup> ]	Length [mm]	Current Ib[A]	P(Ib) [W]
IG	7x300	1000	2820	282,3
I1	240	1600	380	68,5
I2	240	1300	380	55,8
I3	240	1000	380	42,8
I4	120	700	230	21
I5	120	400	230	12

**Total power dissipated by the cables** **482**

Dissipated powers				Dimensions [mm]			0 horiz. segreg.	Temperatures obtained °C		
Busb.	Apparatus	Cables	Tot.	H	L	D		Heights	DMB	Exp.
179	724	482	<b>1385</b>	2000	1650	800	Covered on one side	At top	67	65
								Middle	56	53
								Air	25	25

Versions:  
F = Fixed  
E = Withdrawable

Test N° 8	
Structure	ArTu K
Segregation	Not segregated
Degree of protection	IP65
Assembly	Exposed covered on one side

GENERAL STANDARDS AND CHARACTERISTICS

VERIFYING THE OVERTEMPÉRATURES

PROTECTION AGAINST SHORT-CIRCUIT AND ELECTRIC SHOCKS

PRACTICAL INDICATIONS AND CERTIFICATION AND CONSTRUCTION

CERTIFICATES

DECLARATION OF CONFORMITY



## 7 Checking the overtemperature limits inside ArTu switchgear

7.4 Extracts from test certificates

Single-line diagram

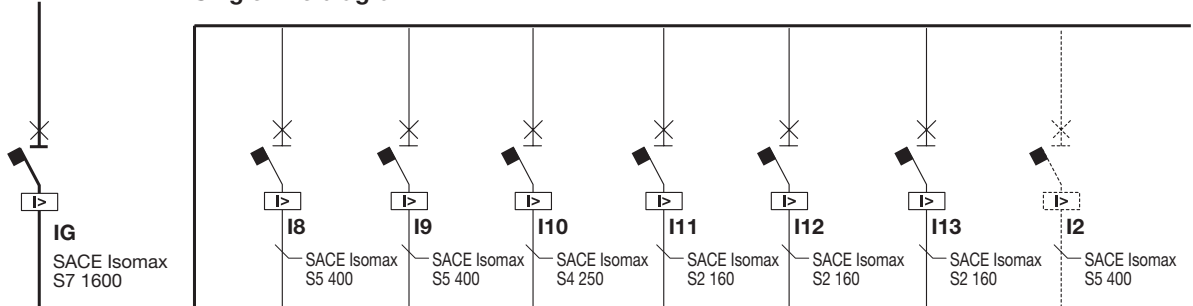

Front of switchgear

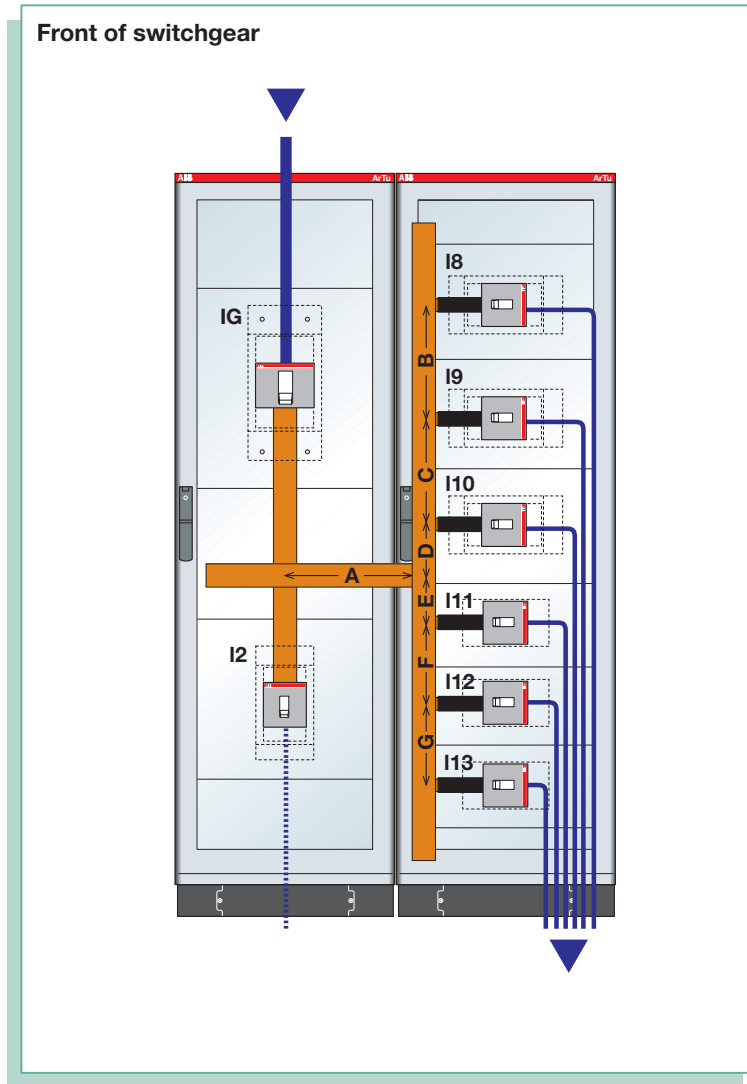

## 7 Checking the overtemperature limits inside ArTu switchgear

7.4 Extracts from test certificates

Circuit-breaker	Type	Terminals	In [A]	Ib [A]	P (Ib) [W]	P (Ib) x C [W]
IG	S7 1600 (F)	Rear	1600	1360	187,9	(x1,3)=244,2
I8	S5 400 (F)	Rear	400	360	48,6	(x1,5)=72,9
I9	S5 400 (F)	Rear	400	360	48,6	(x1,5)=72,9
I10	S4 250 (F)	Rear	250	220	31	(x1,5)=46,5
I11	S2 160 (F)	Rear	160	140	23	(x1,5)=34,5
I12	S2 160 (F)	Rear	160	140	23	(x1,5)=34,5
I13	S2 160 (F)	Rear	160	140	23	(x1,5)=34,5

**Total power dissipated by the circuit-breakers** **540**

Busbar	Cross-section [mm] x [mm]	Length [mm]	Current Ib	P (Ib) [W]
A	2x80x10	360	1360	35,2
B	2x80x10	400	360	2,7
C	2x80x10	400	720	11
D	2x80x10	50	940	2,3
E	2x80x10	150	420	1,4
F	2x80x10	200	280	0,8
G	2x80x10	200	140	negligible

**Total power dissipated by the busbars** **54**

Cable	Cross-section [mm <sup>2</sup> ]	Length [mm]	Current Ib[A]	P(Ib) [W]
IG	4x240	400	1360	55,1
I8	240	1800	360	69,5
I9	240	1400	360	54
I10	95	1000	220	34,2
I11	50	800	140	22,1
I12	50	600	140	16,6
I13	50	400	140	11

**Total power dissipated by the cable** **263**

Dissipated powers				Dimensions [mm]			0 horiz. segreg.	Temperatures obtained °C		
Busb.	Apparatus	Cables	Tot.	H	L	D		Heights	DMB	Exp.
54	540	263	<b>857</b>	2000	1400	800	Covered on one side	At top	66	54
								Middle	56	45
								Air	23	23

Versions:

F = Fixed

E = Withdrawable

Test N° 9	
Structure	<b>ArTu K</b>
Segregation	<b>Form 4</b>
Degree of protection	<b>IP65</b>
Assembly	<b>Exposed covered on one side</b>

GENERAL STANDARDS AND CHARACTERISTICS

VERIFYING THE OVERTEMPÉRATURES

PROTECTION AGAINST SHORT-CIRCUIT AND ELECTRIC SHOCKS

PRACTICAL INDICATIONS AND CERTIFICATION AND CONSTRUCTION

CERTIFICATES

DECLARATION OF CONFORMITY

## 7 Checking the overtemperature limits inside ArTu switchgear

7.4 Extracts from test certificates

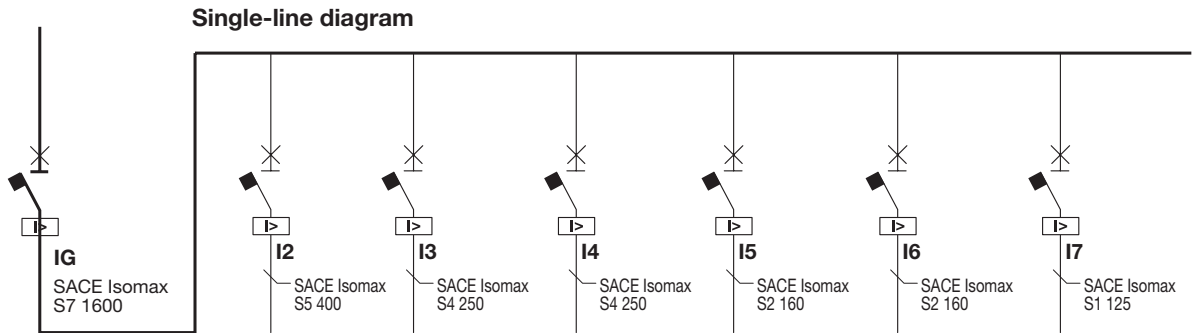

**Front of switchgear**

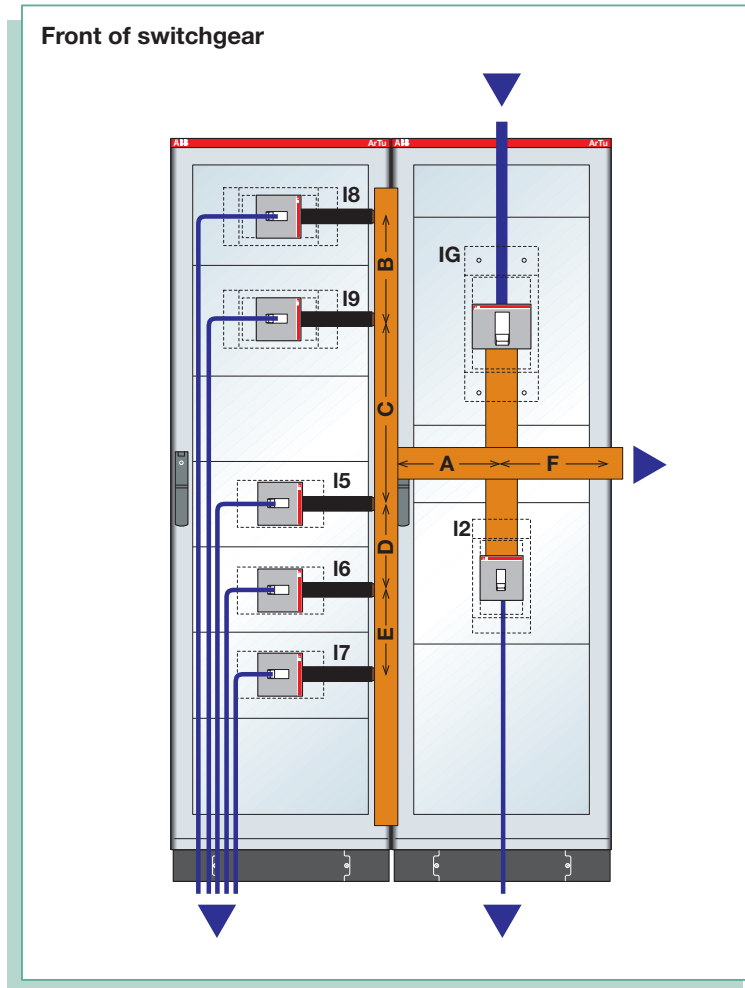

## 7 Checking the overtemperature limits inside ArTu switchgear

7.4 Extracts from test certificates

Circuit-breaker	Type	Terminals	In [A]	Ib [A]	P (Ib) [W]	P (Ib) x C [W]
I <sub>G</sub>	S7 1600 (F)	Rear	1600	1140	132	(x1,3)=171,6
I <sub>2</sub>	S5 400 (F)	Rear	400	360	48,6	(x1,5)=72,9
I <sub>3</sub>	S4 250 (F)	Rear	250	210	28,2	(x1,5)=42,3
I <sub>4</sub>	S4 250 (F)	Rear	250	210	28,2	(x1,5)=42,3
I <sub>5</sub>	S2 160 (F)	Rear	160	130	19,8	(x1,5)=29,7
I <sub>6</sub>	S2 160 (F)	Rear	160	130	19,8	(x1,5)=29,7
I <sub>7</sub>	S1 125 (F)	Rear	125	100	12,2	(x1,5)=19,2

**Total power dissipated by the circuit-breakers** **408**

Busbar	Cross-section [mm] x [mm]	Length [mm]	Current Ib	P (Ib) [W]
A	2x80x10	360	780	11,6
B	40x10	400	210	3,1
C	40x10	400	420	12,4
D	40x10	50	360	1,1
E	40x10	150	230	1,4
F	40x10	200	100	0,3

**Total power dissipated by the busbars** **30**

Cable	Cross-section [mm <sup>2</sup> ]	Length [mm]	Current Ib[A]	P(Ib) [W]
I <sub>G</sub>	4x240	400	1140	38,7
I <sub>2</sub>	240	400	360	15,5
I <sub>3</sub>	95	1800	210	56
I <sub>4</sub>	95	1500	210	47
I <sub>5</sub>	50	1100	130	26,2
I <sub>6</sub>	50	900	130	21,4
I <sub>7</sub>	35	700	100	14,5

**Total power dissipated by the cable** **219**

Dissipated powers				Dimensions [mm]			0 horiz. segreg.	Temperatures obtained °C		
Busb.	Apparatus	Cables	Tot.	H	L	D		Heights	DMB	IP65
30	408	219	<b>657</b>	2000	1400	800	Covered on one side	At top	58	44
								Middle	50	37
								Air	23	23

Test N° 10	
Structure	ArTu K
Segregation	Form 4
Degree of protection	IP65
Assembly	Exposed covered on one side

GENERAL STANDARDS AND CHARACTERISTICS

VERIFYING THE OVERTEMPÉRATURES

PROTECTION AGAINST SHORT-CIRCUIT AND ELECTRIC SHOCKS

PRACTICAL INDICATIONS CERTIFICATION AND CONSTRUCTION

CERTIFICATES

DECLARATION OF CONFORMITY

## 8 Protection against the effects of short-circuit

### 8.1 Checking short-circuit withstand

The electric switchgear must be constructed to resist the thermal and dynamic stresses caused by a short-circuit current up to the assigned values. Furthermore, the switchgear must be protected against short-circuit currents by means of circuit-breakers or fuses which can either be installed in the switchgear or on its supply side.

At the time of ordering, the user must specify the short-circuit conditions at the point of installation.

This chapter considers the following aspects:

- **the need or not to carry out the check on the short-circuit withstand of the switchgear.**
- **suitability of the switchgear for a plant according to the prospective short-circuit current of the plant and the short-circuit parameters of the switchgear.**
- **suitability of a busbar system according to the short-circuit current and to the protection devices.**

### 8.1 Checking short-circuit withstand

The short-circuit withstand check is dealt with by the IEC 60439-1 Standard, and the cases where the check must be carried out and the different types of checks are specified in particular.

Checking the short-circuit withstand is not necessary in the following cases:

- for switchgear which has a rated short-time withstand current or rated conditioned short-circuit current not exceeding 10 kA
- for switchgear protected by current limiting devices with a peak limited current not higher than 17 kA in correspondence with the maximum admissible prospective short-circuit current at the terminals of the incoming circuit of the switchgear
- for the auxiliary circuits of switchgear provided to be connected to transformers whose rated power does not exceed 10 kVA with a rated secondary voltage which is not less than 110 V, or which does not exceed 1.6 kVA with a rated secondary voltage of less than 110 V, and whose short-circuit voltage is not less than 4% in both cases.
- for all the parts of the switchgear (main busbars, main busbar supports, connections to the busbars, incoming and outgoing units, protection and operating apparatus, etc.) which have already undergone type tests valid for the existing conditions.

The need to check the short-circuit withstand can therefore be seen in the following way:

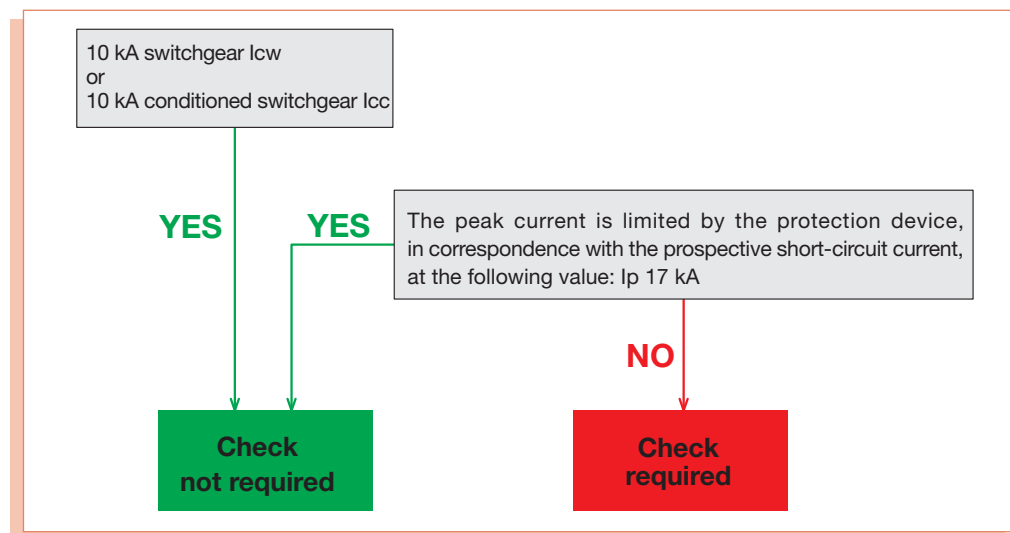

With regard to the details regarding execution of the short-circuit test, we recommend you refer directly to the IEC 60439-1 Standard.

## 8 Protection against the effects of short-circuit

### 8.2 Short-circuit current and suitability of switchgear for the plant

Below there is a table which, according to the circuit-breaker placed to protect the switchgear, provides the maximum value of prospective short-circuit current for which checking the short-circuit withstand is not required..

#### Protection circuit-breaker and short-circuit withstand check

Circuit-breaker		Rated voltage of the plant			
Type	Rated current I <sub>n</sub> [A]	230Vac	415Vac	500Vac	690Vac
S200	≤63	20	10	-	-
S200M	≤63	25	15	-	-
S200P	≤25	40	25	-	-
S200P	32-63	25	15	-	-
S800	≤125	50	50	15(I <sub>n</sub> ≤80A) 10(I <sub>n</sub> ≥80A)	6(I <sub>n</sub> ≤80A) 4.5(I <sub>n</sub> ≥80A)
S290	≤125	25	15	-	-
T1	<160	50	35	15	6
T1	160	37	33	15	6
T2	≤32	120	85	50	10
T2	≤50	120	85	39	10
T2	≤63	120	65	30	10
T2	80-160	120	50	29	10
T3	63	37	20	18	8
T3	80	27	18	17	8
T3	100	21	16	15	8
T3	125-160	18	15	14	8
T3	200-250	16	14	13	8
T4	20	200	200	150	80
T4	32-50	200	200	150	55
T4	80	200	100	48	32
T4	100-320	200	24	21	19
T5 T6 T7	320-1600	10	10	10	10

The short-circuit current value reported in the table above must be compared with the breaking capacity of the circuit-breaker for the different versions available.

### 8.2 Short-circuit current and suitability of switchgear for the plant

Checking the short-circuit withstand current is based on two values:

- the short-time short-circuit withstand current I<sub>cw</sub>
- the conditioned short-circuit current I<sub>cc</sub>.

According to the two values, it is possible to establish whether the switchgear is suitable or not for being installed in a certain point of the plant.

It must, of course, be verified that the breaking capacities of the apparatus (if necessary by means of back-up) inside the switchgear are compatible with the short-circuit values of the plant.

The **short-time short-circuit withstand current** I<sub>cw</sub> is an established r.m.s. current test value, which a certain initial peak value corresponds to, which is applied to the test circuit of the switchgear for a certain time (generally 1s). The switchgear must manage to withstand the thermal and electrodynamic stresses without any breakages or deformation which jeopardise functionality of the system. From this test (if passed), it is possible to find the specific let-through energy (I<sup>2</sup>t) which the switchgear can withstand:

$$I^2t = I_{cw}^2t$$

The peak value of the short-circuit current can be determined by multiplying the r.m.s. value of the short-circuit current by factor "n" according to table 4 of IEC 60439.

$$I_p = I_{cw} \cdot n$$

R.m.s. value of the short-circuit current	cosφ	n
I ≤ 5 kA	0,7	1,5
5 < I 10 kA	0,5	1,7
10 < I 20 kA	0,3	2
20 < I 50 kA	0,25	2,1
50 < I	0,2	2,2

The **conditioned short-circuit current** is an established r.m.s. current test value, which a certain initial peak value corresponds to, which can be withstood by the switchgear for the trip time of a specific piece of protection apparatus. This apparatus is usually the main switchgear circuit-breaker.

By means of the two I<sub>cw</sub> and I<sub>p</sub> values and the value of prospective short-circuit current of the plant, it is possible to establish whether the switchgear is suitable or not for being installed in the plant.

The values in Table 4 take into account the majority of applications. In particular areas, e.g. near transformers or generators, the power factor can take on lower values so, in these cases, the maximum peak value of the prospective current can become the limiting factor, instead of the short-circuit current r.m.s. value.

## 8 Protection against the effects of short-circuit

8.2 Short-circuit current and suitability of switchgear for the plant

The following diagrams show the method to determine compatibility of the switchgear with the plant.

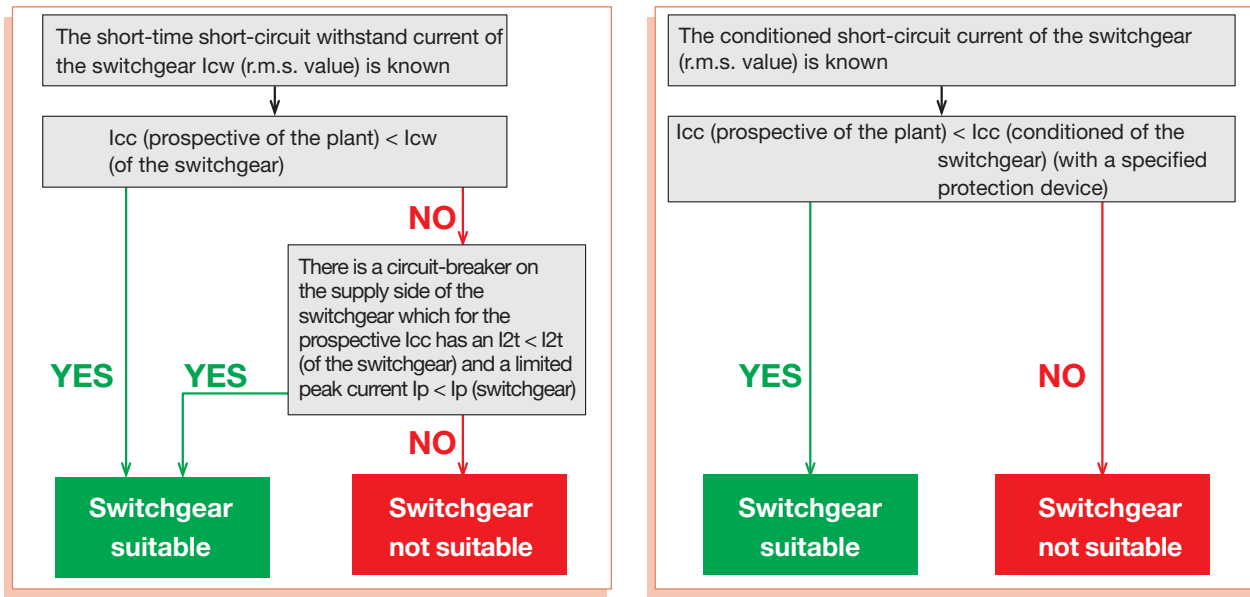

*It must, of course, be checked that the breaking capacities of the apparatus inside the switchgear are compatible with the short-circuit values of the plant.*

### Example

Existing plant data:  $V_n=400\text{ V}$   
 $f_n=50\text{ Hz}$   
 $I_{cc}=35\text{ kA}$

Let us suppose that in an existing plant there is electric switchgear with an  $I_{cw}$  of 35kA and that, in the installation point of the switchgear, the prospective short-circuit current is 35kA.

Now let us imagine that it is decided to extend the power of the plant and that the short-circuit value increases to 60 kA.

Plant data after

extension:  $V_n=400\text{ V}$   
 $f_n=50\text{ Hz}$   
 $I_{cc}=60\text{ kA}$

Since the switchgear  $I_{cw}$  is lower than the short-circuit current of the plant, to check that the existing switchgear is still compatible, you must:

- determine the values of  $I^2t$  and of  $I_p$  let through by the circuit-breaker placed on the supply side of the switchgear
- check that the protection devices located inside the switchgear have adequate breaking capacity, individually or for back-up.

$I_{cw} = 35\text{ kA}$  from which:

$$I^2t_{\text{switchgear}} = 35^2 \times 1 = 1225 \text{ MA}^2\text{s}$$

$$I_p_{\text{switchgear}} = 73.5 \text{ kA}$$

Let us suppose that, on the supply side of the switchgear, a Tmax T5H moulded-case circuit-breaker ( $I_{cu}=70\text{ kA}@415\text{ V}$ ) is installed

$$I^2t_{\text{interruttore}} < 4\text{ MA}^2\text{s}$$

$$I_p_{\text{interruttore}} < 40\text{ kA}$$

since

$$I^2t_{\text{circuit-breaker}} > I^2t_{\text{switchgear}}$$

$$I_p_{\text{circuit-breaker}} > I_p_{\text{switchgear}}$$

The switchgear (structure and busbar system) turns out to be suitable.

With regard to the circuit-breakers located inside the switchgear, let us suppose that these are Tmax T1, T2, T3 moulded-case circuit-breakers, version N with  $I_{cu}=36\text{ kA}@415\text{ V}$ . From the Back-up tables it can be seen that the circuit-breakers present in the switchgear are suitable for the plant as their breaking capacity is increased to 65 kA by the T5H circuit-breaker placed on the supply side.

## 8 Protection against the effects of short-circuit

8.3 Distribution system selected in relation to the short-circuit withstand current

### 8.3 Distribution system selected in relation to the short-circuit withstand current

The distribution system of the switchgear is sized by taking into consideration the rated current which passes through it and the prospective short-circuit current of the plant.

There are normally tables provided by the manufacturer which make it possible to select the cross-section of the busbar, according to the rated current, and which provide the distances the busbar holder supports must be placed at to guarantee the short-circuit withstand current.

The distribution systems which can be used inside the ArTu switchgear are given in ABB Sace's technical "Distribution Switchgear General Catalogue", and these are:

- busbars with shaped section up to 4000 A
- drilled flat busbars up to 4000 A
- flexible busbars up to 1000 A
- Unifix cabling system up to 400 A
- distribution frames up to 400 A.

Apart from the rated current of the system, the catalogue also gives the short-time short-circuit withstand current value  $I_{cw}$ .

To select the distribution system compatible with the short-circuit data of the plant, the following procedure must be followed:

- **If the protection device placed on the supply side of the distribution system under examination is known**

From the  $I_{cw}$  value of the distribution system the following is obtained:

$I_{p_{syst}} = I_{cw} \cdot n$  where  $n$  is the factor taken from Table 4 on page 45

$I^2t_{syst} = I_{cw}^2 \cdot t$  where  $t$  is equal to 1 second

In correspondence with the prospective short-circuit current value of the plant the following is determined:

The value of the peak current limited by the circuit-breaker  $I_{p_{cb}}$

The specific energy let through by the circuit-breaker  $I^2t_{cb}$

If  $I_{p_{cb}} < I_{p_{syst}}$  and  $I^2t_{cb} < I^2t_{syst}$  then the distribution system is suitable.

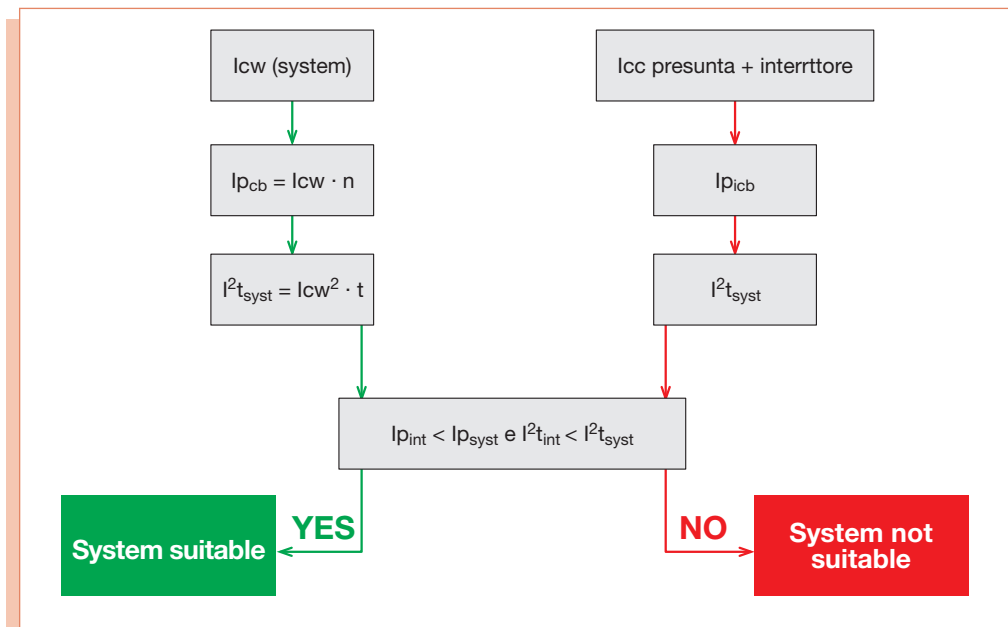

- **If the protection device placed on the supply side of the distribution system under examination is not known it must be checked that:**

$I_{cc} \text{ (prospective)} < I_{cw} \text{ (system)}$



## 8 Protection against the effects of short-circuit

8.3 Distribution system selected in relation to the short-circuit withstand current

### Example

Plant data:  $V_n=400\text{ V}$   
 $f_n=50\text{ Hz}$   
 $I_{cc}=65\text{ kA}$

Let us suppose that the use of a 400 A busbar system with shaped section is needed. From the ABB SACE "Distribution Switchgear General Catalogue", a possible selection might be:

BA0400       $I_n$  400 A (IP65)       $I_{cw}$  35kA.

Let us suppose that, on the supply side of the busbar system, there is a moulded-case circuit-breaker:

Tmax T5400 R400

From the  $I_{cw}$  of the busbar system it is found that:

$$I_{p_{\text{sys}}} = I_{cw} \cdot 2,1 = 73,5 \quad [\text{kA}]$$
$$I^2t_{\text{sys}} = I_{cw}^2 \cdot t = 35^2 \cdot 1 = 1225 \quad [(\text{kA})^2\text{s}]$$

From the limitation and specific energy curves of the T5400 R400

A  $I_{cc}$  65kA corresponds to  $I_{p_{cb}} < 40\text{ kA}$   
corresponds to  $I^2t_{cb} < 5 [(\text{kA})^2\text{s}] = 5 [\text{MA}^2\text{sec}]$

Therefore it turns out that:

Since

$$I_{p_{cb}} < I_{p_{\text{sys}}}$$

e

$$I^2t_{cb} < I^2t_{\text{sys}}$$

the busbar system is compatible with the plant.

## 8 Protection against the effects of short-circuit

8.3 Distribution system selected in relation to the short-circuit withstand current

### Pieces of conductor on the supply side of the device

The 60439-1 Standard states that inside switchgear, the conductors (including the distribution busbars) placed between the main busbars and the supply side of the individual functional units, as well as the components making up these units, can be sized on the basis of the reduced short-circuit stresses which are produced on the load side of the short-circuit protection device of the unit.

This is possible if the conductors are arranged so that, under normal service conditions, the internal short-circuit between phases and/or between phases and earth is to be considered a remote possibility. It is preferable for these conductors to be of massive and rigid construction.

As an example, the standard indicates conductors and prescriptions for the installation which allow the remote hypothesis of a short-circuit between phases and/or between phases and earth to be considered.

Type of conductor	Prescription for the installation
Bare conductors, or conductors with a single core with main insulation, for example cables conforming to IEC 60227-3	Reciprocal contact or contact with conductive parts must be avoided, for example by using spacers
Conductors with a single core with main insulation and a maximum admissible temperature for operation of the conductor higher than 90° C, for example cables conforming to IEC 60245-3, or cables insulated in PVC resistant to heat conforming to IEC 60227-3	Reciprocal contact or contact with conductive parts is allowed where no external pressure is exerted. Contact with sharp edges must be avoided. There must not be a risk of mechanical damage. These conductors can only be supplied so that an operating temperature of 70 °C is not exceeded.
Conductors with main insulation, for example cables conforming to IEC 60227-3, with a secondary supplementary insulation, for example individually covered with a shrink-on sheath or placed individually in tubes made of plastic material	There is no supplementary prescription if there is no risk of mechanical damage.
Conductors insulated with material with high mechanical resistance, for example FTFE insulation, or conductors with double insulation with an external reinforced sheath for use up to 3 kV, for example the cables conforming to IEC 60502.	
Covered cables with a single core or with several cores, for example cables conforming to IEC 60245-4 or 60227-4.	

If these conditions are found, or in any case when an internal short-circuit can be considered a remote hypothesis, the procedure described above can be used to check suitability of the distribution system for the short-circuit conditions, where these are determined according to the characteristics of the circuit-breaker placed on the load side of the busbars.

## ► 8 Protection against the effects of short-circuit

8.3 Distribution system selected in relation to the short-circuit withstand current

### Example

Plant data:  $V_n=400\text{ V}$   $f_n=50\text{ Hz}$   $I_{cc}=45\text{ kA}$

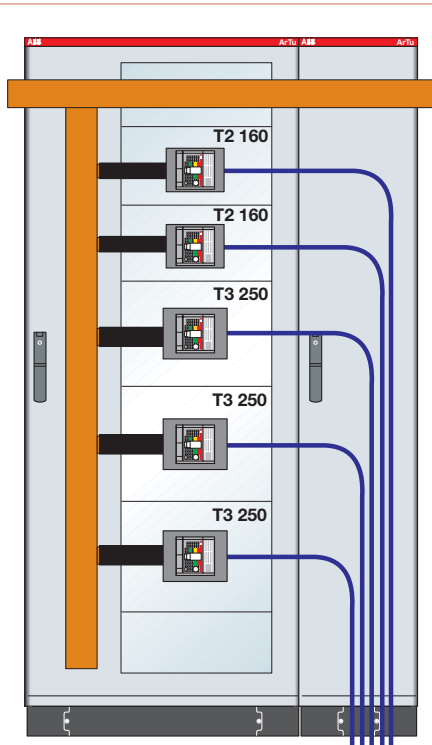

Let us consider the switchgear in the figure, from where the vertical distribution busbars are branched from the main busbars.

These are 800 A busbars with shaped section as indicated in the Distribution Switchgear General Catalogue:

$I_n$  (IP65) 800,

$I_{cw\ max}$  35 kA

Being a rigid system with spacers, for the CEI EN 60439 Standard, the short-circuit between the busbars is a remote hypothesis.

It must, in any case, be checked that the stresses reduced by the circuit-breakers located on the load side of the system are compatible with the system.

Let us suppose that the following are in the compartments

$T_{max}$  T3S250

$T_{max}$  T2S160

It must be checked that, in the case of a short-circuit on any output, the limitations produced by the circuit-breaker, are compatible with the busbar system.

It must therefore be checked that the circuit-breaker which limits the peak and energy least, in any case limits it sufficiently for the busbar system.

In our case this is the T3S250  $I_n=250$

Therefore we carry out the check in the same way as in the previous paragraph:

From the  $I_{cw}$  of the busbar system it turns out that:

$$I_{p_{syst}} = I_{cw} \cdot n = 35 \cdot 2.1 = 73.5 \quad [\text{kA}]$$

$$I^2t_{syst} = I_{cw}^2 \cdot t = 35^2 \cdot 1 = 1225 \quad [(\text{kA})^2\text{s}]$$

From the limitation and specific let-through energy curves.

With  $I_{cc}$  45kA here is corresponding  $I_{pcb} < 30\text{ kA}$

which corresponds with  $I^2t_{cb} < 2 [(\text{kA})^2\text{s}]$

It therefore turns out that:

Since

$$I_{p_{cb}} < I_{p_{syst}}$$

e

$$I^2t_{cb} < I^2t_{syst}$$

the busbar system is compatible with the switchgear.

## 9 Protection against electric shocks

### 9.1 Protection against the direct contacts - 9.2 Protection against the indirect contacts

The prescriptions which follow are aimed at ensuring that the protective measures required are taken when the switchgear is installed in the electrical plant, conforming to the relative standards.

#### 9.1 Protection against the direct contacts

Protection against the direct contacts can be obtained both by means of the switchgear construction itself, and by means of complementary measures to be used during installation. The protection measures against direct contacts are:

##### - Protection by means of insulation of the live parts

The live parts must be completely covered with insulation which can only be removed by destroying it.

This insulation must be made of suitable materials able to resist the mechanical, electrical and thermal stresses they may be subjected to during service over time.

Paints, varnishes, lacquers and other similar products used alone are not generally considered suitable for providing adequate insulation for protection against direct contacts.

##### - Protection by means of barriers or housings

All the external surfaces must have a degree of protection of at least IP2X or IPXXB.

The distance between the mechanical devices provided for protection and the live parts protected by them, must not be less than the values specified for the surface and air distances.

All the barriers and housings must be securely fixed in place. Bearing in mind their type, size and arrangement, they must be sturdy and long-lasting enough to resist the forces and stresses which can develop during normal service, without reducing the air insulation distances.

##### - Protection by means of obstacles

This protection is applicable to open type switchgear.

#### 9.2 Protection against the indirect contacts

The user must indicate the protection measure regarding the installation the switchgear is destined for.

The measures of protection against indirect contacts are:

##### - Protection made using protection circuits

The protection circuit can be made separate from the metal housing, or the same housing can be used as part of the protection circuit.

The exposed conductive parts of the switchgear which do not constitute a danger, since they cannot be touched on large surfaces or taken hold of by hand because they are small (for example, screws, nameplates, etc.), do not require connection to the protection circuit.

The manual operating parts, such as levers, handles and other devices made of metal, must, on the other hand, be connected securely to the parts connected to the protection circuit or must have additional insulation suitable for the maximum insulation voltage of the switchgear.

The metal parts coated with a layer of paint or enamel cannot normally be considered suitably insulated to satisfy these prescriptions.

For covers, doors, closure plates, etc., the normal connections made using metal screws or hinges are sufficient for electrical continuity, as long as electrical apparatus which requires a connection of the exposed conductive parts to earth is not mounted on them. In this case, the exposed conductive parts must be connected by means of a protection conductor with a cross-section at least the same as the maximum cross-section of the phase conductor supplying the apparatus.

## 9 Protection against electric shocks

### 9.2 Protection against the indirect contacts

The cross-section of the protection conductors (PE, PEN) destined to be connected to external conductors in switchgear must be determined using one of the following methods:

- a) The cross-section of the protection conductor must not be less than the one specified in the table. The table can be used for PEN conductors if it is assumed that the neutral currents do not exceed 30% of the phase currents.

Cross-section of the phase conductor <b>S</b> (mm <sup>2</sup> )				Minimum cross-section of the corresponding protection conductor <b>S</b> (mm <sup>2</sup> )	
		S	≤	16	S
16	<	S	≤	35	16
35	<	S	≤	400	S/2
400	<	S	≤	800	200
		S	≤	800	S/4

If a non-standard value results from application of this table, the larger standardised cross-section closest to the value calculated must be used.

The values in the table are only valid if the protection conductor (PE, PEN) is made of the same material as the phase conductor. Otherwise, the cross-section of the protection conductor (PE, PEN) must be determined so as to obtain a conductance equivalent to the one resulting from application of the table.

For PEN conductors, the following additional prescriptions must also be applied:

- the minimum cross-section must be 10 mm<sup>2</sup> for a copper conductor and 16 mm<sup>2</sup> for an aluminium conductor;
- it is not necessary for PEN conductors to be insulated inside the switchgear;
- parts of the structure must not be used as a PEN conductor. However, mounting rails made of copper or aluminium can be used as PEN conductors;
- for some applications, for which the current in the PEN conductor can reach high values, for example in large lighting installations with fluorescent lamps, a PEN conductor with the same capacity as the phase conductors or a higher capacity may be required. This must be the subject of a special agreement between the manufacturer and the user.

- b) The cross-section of the protection conductor (PE, PEN) can be calculated with the help of the following formula:

$$S_p = \frac{\sqrt{I^2 t}}{k}$$

The formula is used to calculate the cross-section of the protection conductors required to withstand the thermal stresses caused by currents lasting a time between about 0.2s and 5s, where:

**S<sub>p</sub>** is the area of the cross-section expressed in mm<sup>2</sup>;

**I** is the r.m.s. value of the fault current (in AC) which passes through the protection device, expressed in A, for a negligible impedance fault;

**t** is the trip time of the breaking device, in seconds;

**k** is a factor whose value depends on the material of the protection conductor, on the insulation and on other elements, as well as on the initial and final temperature.

## 9 Protection against electric shocks

### 9.2 Protection against the indirect contacts

Factor k values for insulated protection conductors not incorporated in bare protection cables or conductors in contact with cable coatings.

		PVC	XLPE	EPR	Bare conductors	Butyl rubber
<i>Final temperature</i>		160 °C			250 °C	220 °C
<b>K</b> for	copper	143			176	166
conductor	aluminium	95			116	110
	steel	52			64	60

Note: it is presumed that the initial temperature of the conductors is 30 °C.

The accessible conductive parts of a device, which cannot be connected to the protection circuit by means of its own connection means, must be connected to the protection circuit of the switchgear by means of an equipotential conductor, whose cross-section must be selected according to the following table:

Cross-section of the service conductor				Minimum cross-section of the equipotential protection conductor	
$I_n$ (A)				(mm <sup>2</sup> )	
		$\leq$	20	S	
20	<	$\leq$	25	2,5	
25	<	$\leq$	32	4	
32	<	$\leq$	63	6	
63	<	$\leq$		10	

#### - Protection realized with measures other than the use of protection circuits

The electric switchgear can provide protection against indirect contacts by means of the following measures which do not require a protection circuit:

- electric separation of the circuits
- full insulation.

## ► 10 Practical indications for constructing the switchgear

10.1 Positioning the circuit-breakers

### 10.1 Positioning the circuit-breakers

With regard to positioning the circuit-breakers inside the switchgear, there are some indications which are in contrast with each other. This is because requirements of thermal type often contrast with the needs of another kind. It is therefore the panel builder who, knowing the plant details, its installation location and its actual use better, can design the front of the switchgear in an optimal way.

- A good rule is to try to position the circuit-breakers so as to reduce the higher current paths as far as possible, thereby reducing the power dissipated inside the switchgear with undoubted benefits from the thermal and economic points of view.

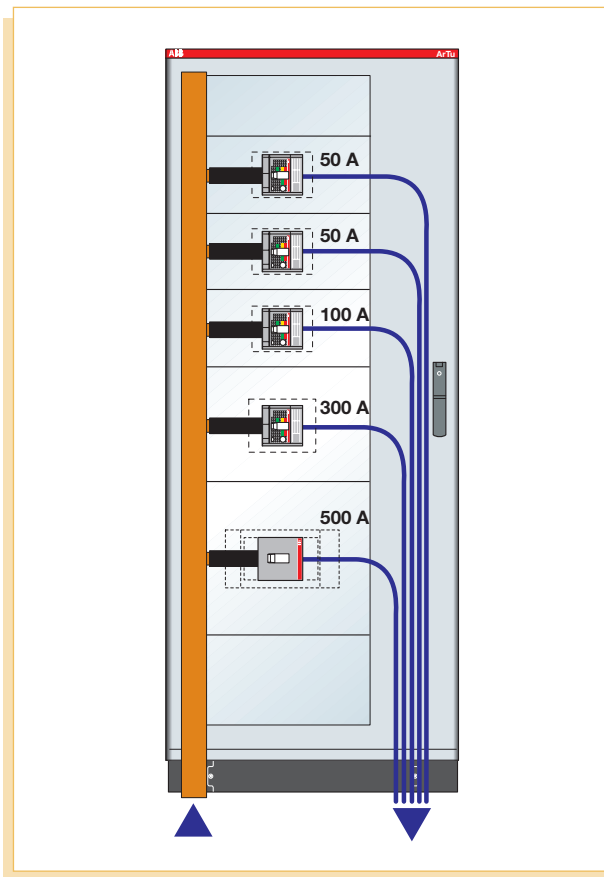

**Recommended positioning method:**  
The HIGHEST current (500 A) takes the SHORTEST path

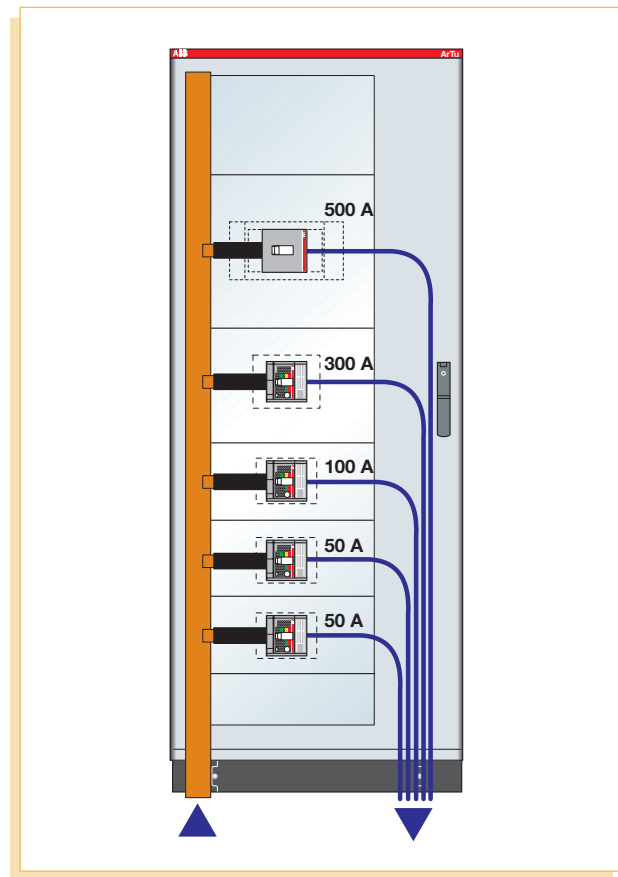

**Positioning method NOT recommended:**  
The HIGHEST current (500 A) takes the LONGEST path

## ► 10 Practical indications for constructing the switchgear

### 10.1 Positioning the circuit-breakers

- In the case of switchgear with a lot of columns, where possible it is advisable to position the main circuit-breaker in the central column. This way the current is immediately divided into the two branches of the switchgear and the cross-section of the main distribution busbars can be reduced.

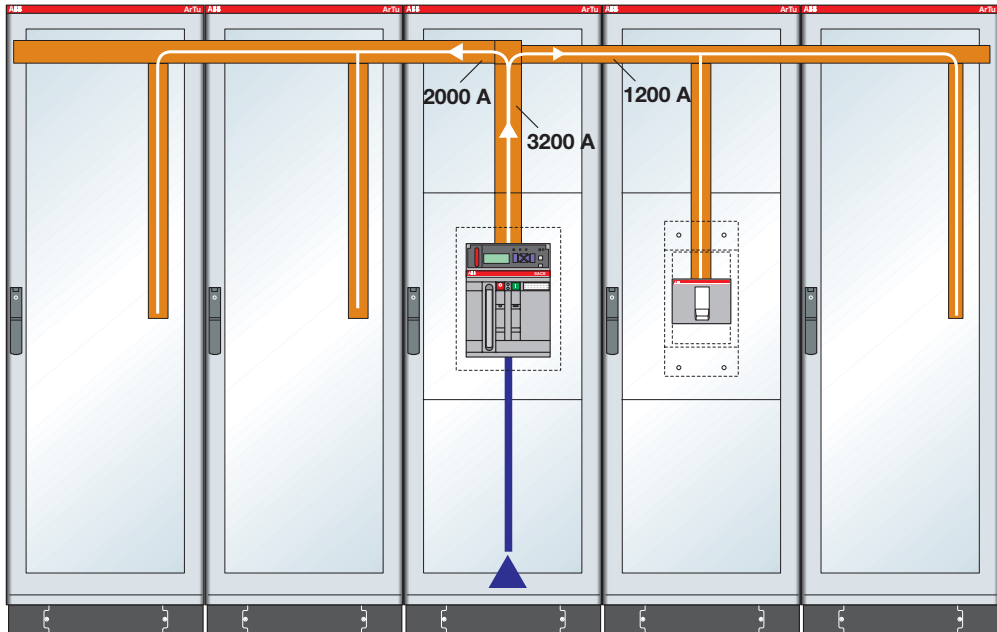

In the example given in the figure, the main busbar system can be sized for 2000 A, with considerable economic benefits.

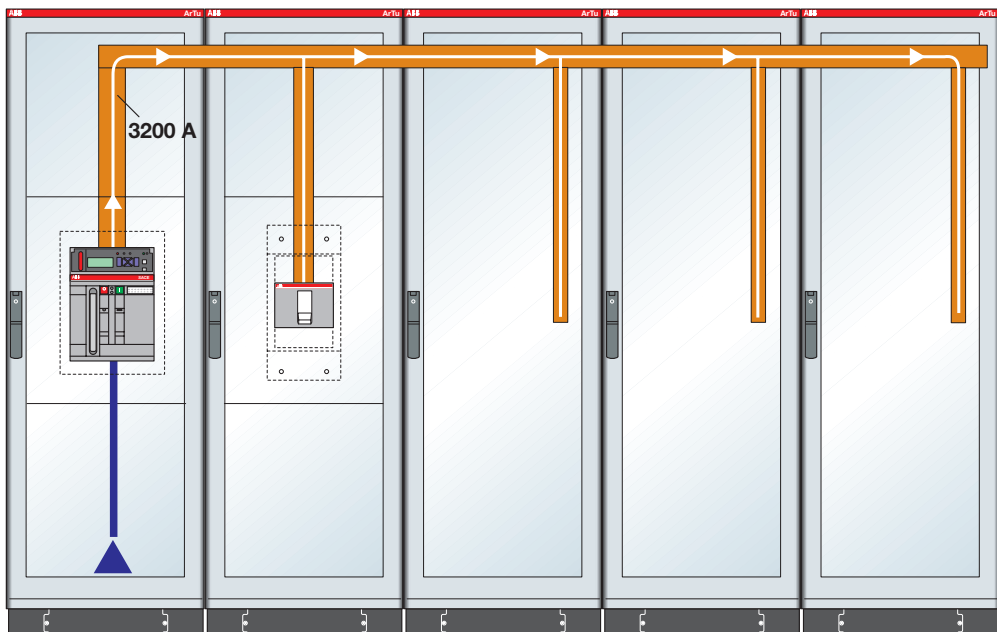

In this case, on the other hand, the main busbar system must be sized to carry 3200 A.

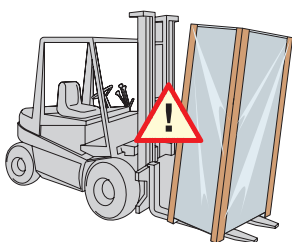

- It is advisable to position the largest and therefore the heaviest circuit-breakers at the bottom. This allows greater stability of the switchgear, especially during transport and installation.



## ▶ 10 Practical indications for constructing the switchgear

10.1 Positioning the circuit-breakers - 10.2 Anchoring the conductors near the circuit-breakers

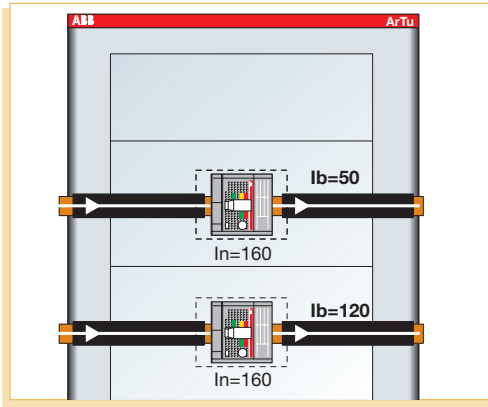

- In electric switchgear the temperature varies vertically:
  - the lower areas are the coldest,
  - the higher areas are the hottest.

For this reason it is advisable to place the apparatus passed through by a current close to the rated value (more loads) at the bottom and the apparatus passed through by a current a long way from the rated value (more discharges) at the top.

- To facilitate operation of large apparatus, it is advisable to place this between 0.8 m and 1.6 m from the ground

### 10.2 Anchoring the conductors near the circuit-breakers

It is necessary for the cables and busbars to be fixed to the structure inside the switchgear. In fact, during a short-circuit, the dynamic stresses produced in the conductors could damage the terminals of the circuit-breakers.

#### Emax

In the Emax air circuit-breaker installation manual, the maximum distances (in mm) of the busbar anchor plates are indicated according to the type of terminal:

Emax X1

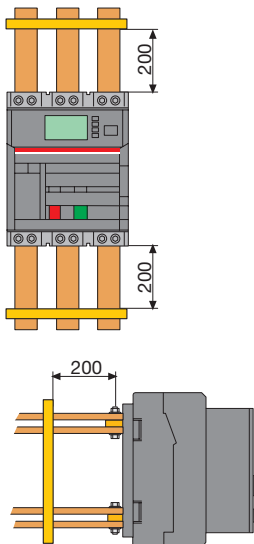

Emax E1-E4

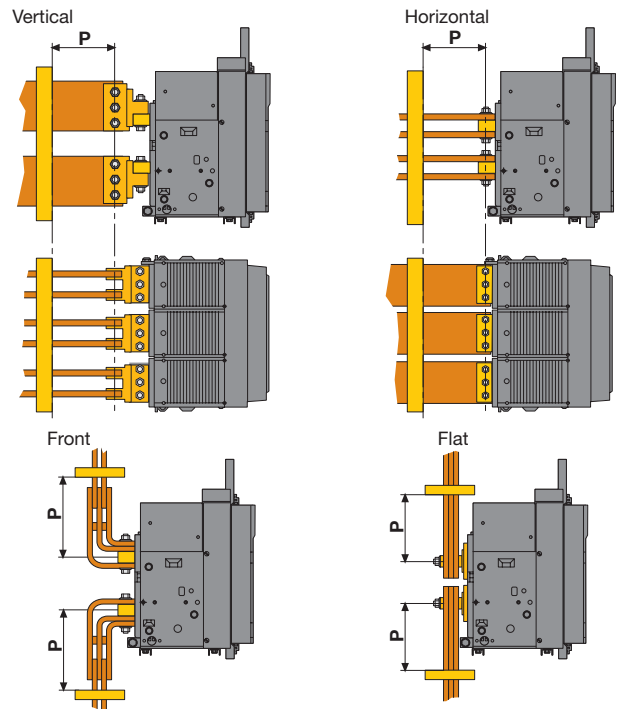

	Horizontal P [mm]	Vertical P [mm]	Front P [mm]	Flat P [mm]
<b>Emax</b>				
<b>E1-E2</b>	250	250	-	-
<b>E3-E4</b>	150	150	-	-
<b>E1-E4</b>	-	-	250	250

## ► 10 Practical indications for constructing the switchgear

10.2 Anchoring the conductors near the circuit-breakers

### Tmax (T1...T7)

The maximum distance at which to place the first anchor plate for Tmax moulded-case circuit-breakers is given.

Tmax T1

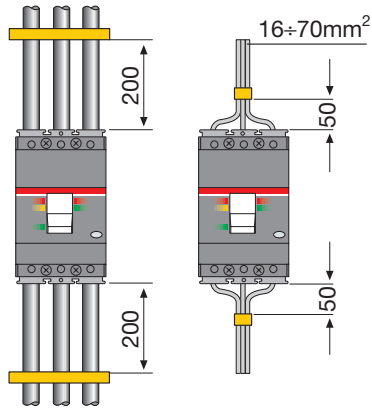

Tmax T2

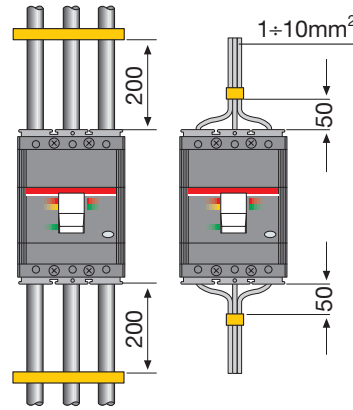

Tmax T3

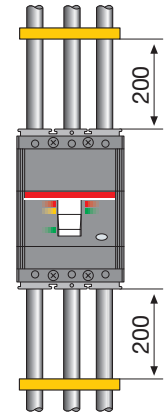

Tmax T4

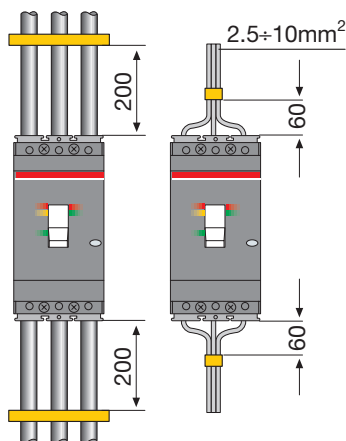

Tmax T5

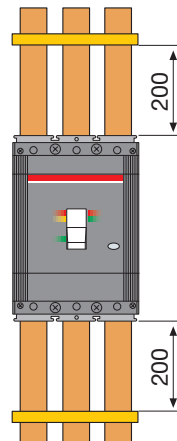

Tmax T6

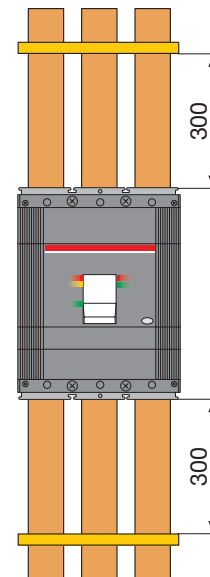

Tmax T7

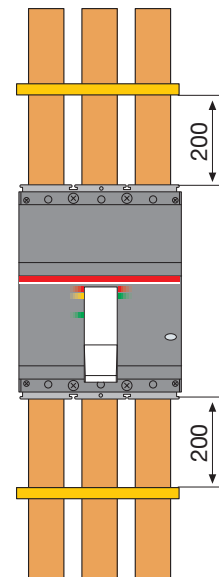

GENERAL  
STANDARDS AND  
CHARACTERISTICS

VERIFYING THE  
OVERTEMPATURES

PROTECTION AGAINST  
SHORT-CIRCUIT AND  
ELECTRIC SHOCKS

PRACTICAL INDICATIONS  
CERTIFICATION AND  
CONSTRUCTION

CERTIFICATES

DECLARATION OF  
CONFORMITY

## ► 10 Practical indications for constructing the switchgear

### 10.2 Anchoring the conductors near the circuit-breakers

In the case of connections by means of rigid busbars, the maximum distance can be increased as the peak of the prospective short-circuit current decreases. The graphs which give the maximum fixing distance according to the maximum prospective short-circuit current peak are indicated below.

It should be remembered that to determine the peak of a short-circuit current, coefficient  $n$  of table 4 on page 45 can be used.

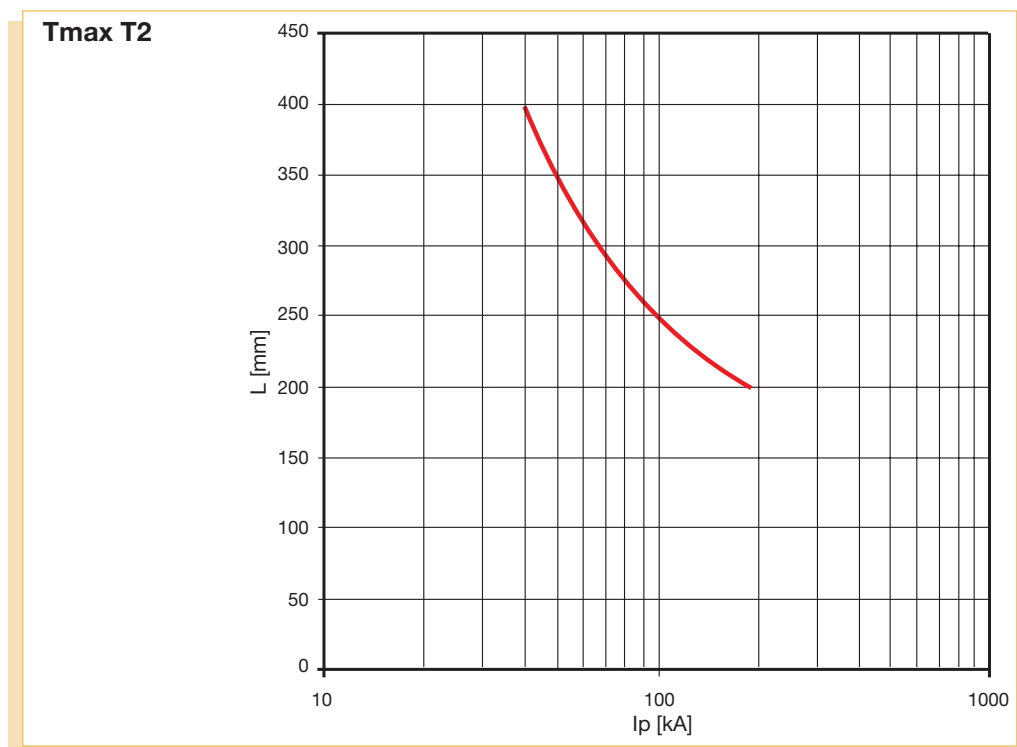
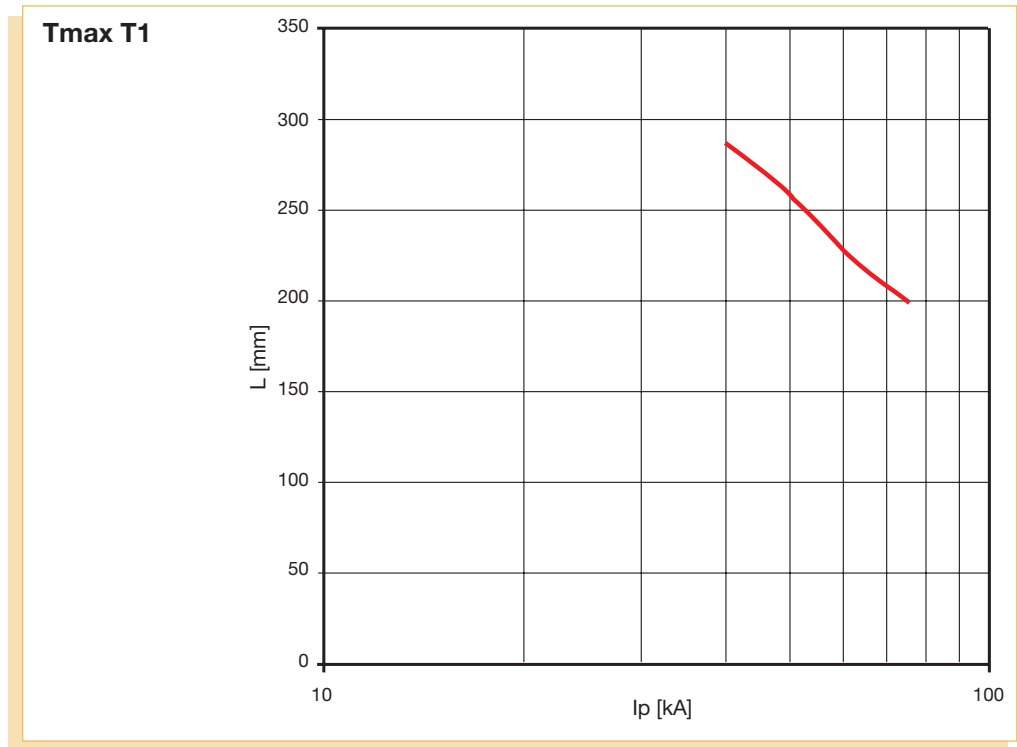

## 10 Practical indications for constructing the switchgear

10.2 Anchoring the conductors near the circuit-breakers

GENERAL  
STANDARDS AND  
CHARACTERISTICS

VERIFYING THE  
OVERTEMPÉRATURES

PROTECTION AGAINST  
SHORT-CIRCUIT AND  
ELECTRIC SHOCKS

PRACTICAL INDICATIONS  
CERTIFICATION AND  
CONSTRUCTION

CERTIFICATES

DECLARATION OF  
CONFORMITY

**Tmax T3**

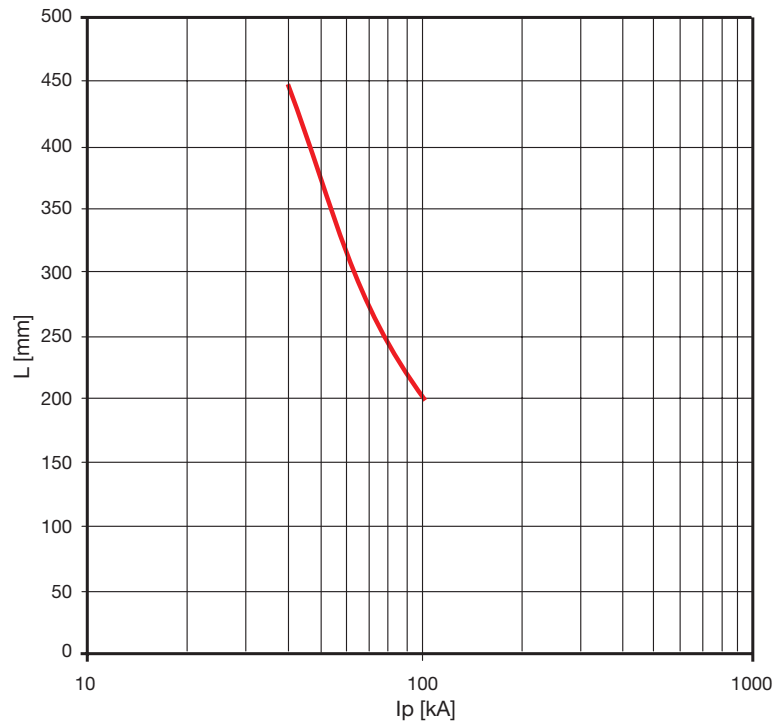

- \* Valid for:
- front and rear terminals
  - connection by means of rigid busbars.

**Tmax T4 - T5\***

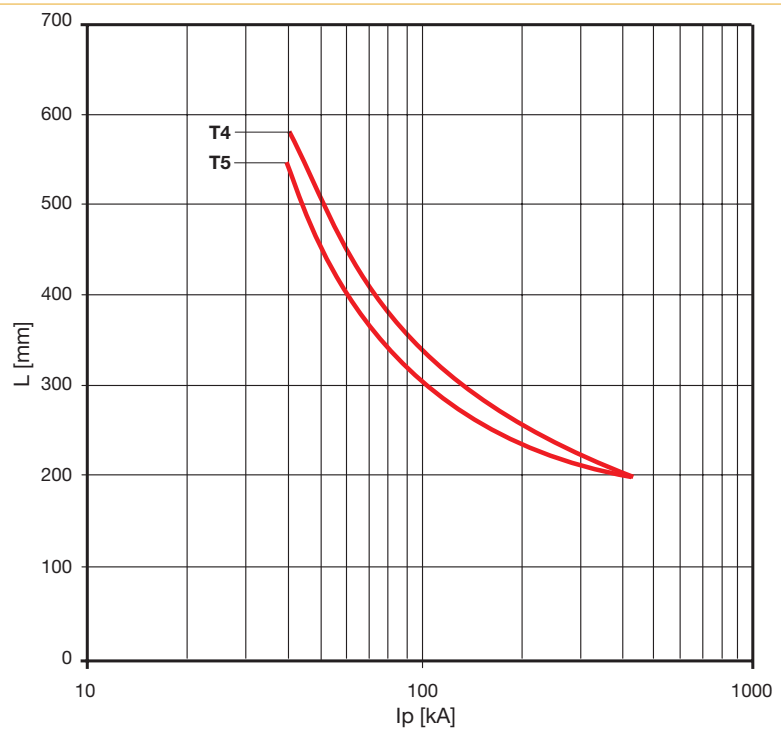

## ► 10 Practical indications for constructing the switchgear

10.2 Anchoring the conductors near the circuit-breakers

### SACE Tmax T6

The maximum distance at which to place the first anchor plate according to the peak of the prospective short-circuit current is given for Isomax moulded-case circuit-breakers.

**Tmax T6**

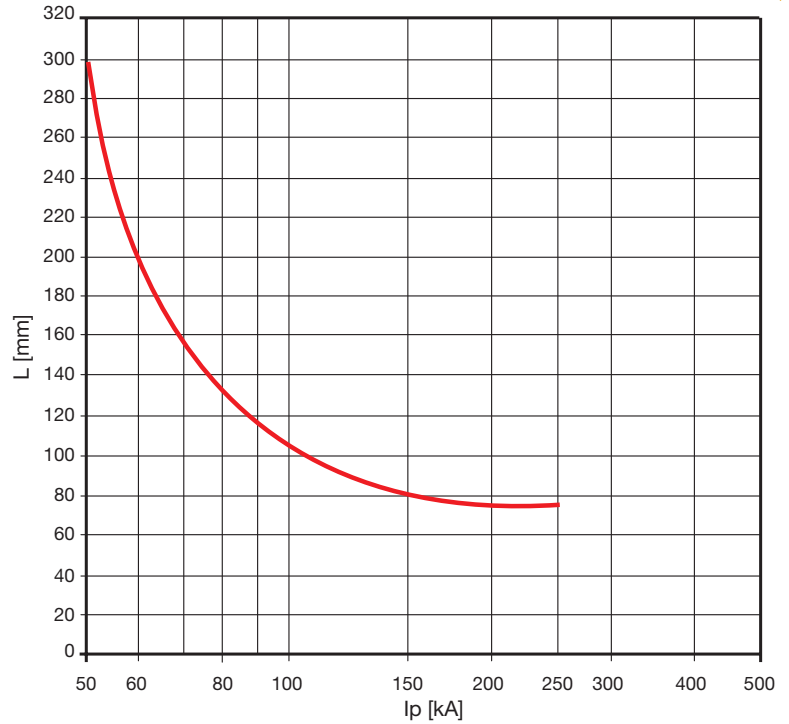

**Emax**

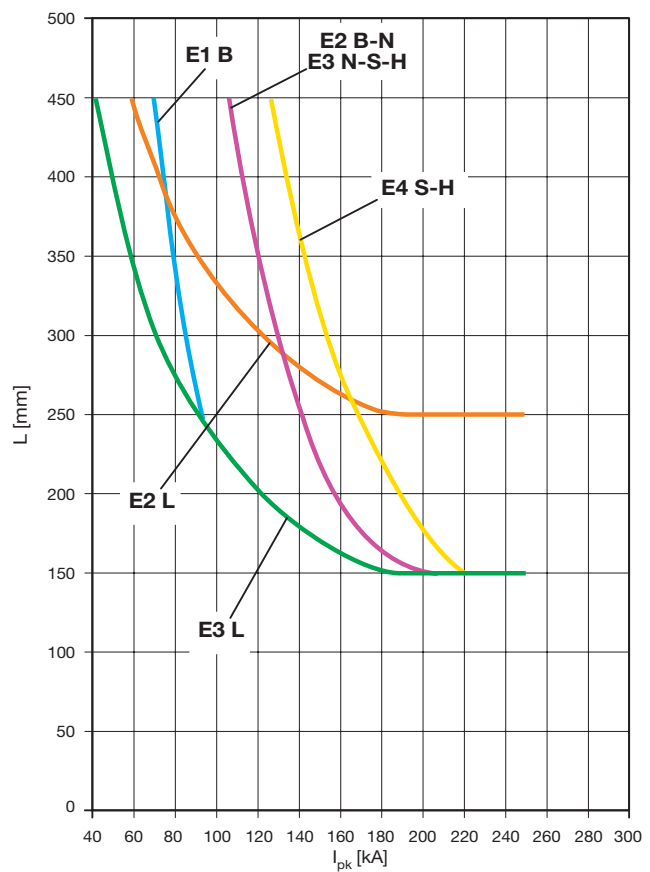

## ► 11 Guide to certification according to the IEC 60439-1 Standard

11.1 Introduction

### 11.1 Introduction

First of all, the list of the tests and checks for AS and ANS switchgear required by the IEC 60439-1 Standard is given.

N	Characteristics to be verified	TTA	PTTA
1	Overtemperature limit	Checking by means of tests (type test)	Verification tests or extrapolation
2	Dielectric properties	Checking the dielectric properties by means of testing (type test)	Verification by means of tests 8.2.2 or 8.3.2 or by checking the insulation resistance according to 8.3.4
3	Short-circuit withstand	Checking the short-circuit withstand by means of tests (type test)	Checking the short-circuit withstand by means of tests or extrapolation from arrangements of AS or similar switchgear which have passed the type test
4	Short-circuit withstand of the protection circuit	Checking effective connection of the switchgear exposed conductive parts and the protection circuit, by means of inspection or measurement of the resistance (type test)	Checking effective connection of the switchgear exposed conductive parts and the protection circuit, by means of inspection or measurement of the resistance
5		Checking the protection circuit short-circuit withstand by means of testing (type test)	Checking the protection circuit short-circuit withstand by means of testing or suitable design and arrangement of the protection conductor
6	Air and surface insulation distances	Checking the air and surface insulation distances (type test)	Checking the air and surface distances
7	Mechanical operation	Checking mechanical operation (type test)	Checking mechanical operation
8	Degree of protection	Checking the degree of protection (type test)	Checking the degree of protection
9	Cabling, electrical operation	Inspection of the equipment including inspection of cabling and, if necessary, the electrical operation test (individual test)	Inspection of the equipment including inspection of cabling and, if necessary, the electrical operation test
10	Insulation	Dielectric test (individual test)	Dielectric test or checking the insulation resistance according to 8.3.4 (see n° 9 and 11)
11	Protection measures	Checking the protection measures and electrical continuity of the protection circuit (individual test)	Checking the protection measures
12	Insulation resistance		Checking the insulation resistance if the tests have not been carried out according to 8.2.2 or 8.3.2 (see n° 2 and n° 9)

The ABB SACE ArTu switchgear is an established construction system, already subjected to a series of tests, which allow TTA or PTTA type switchgear to be constructed without carrying out any type tests but simply the individual tests (switchgear testing). To obtain this, it is necessary to use ABB SACE metal structures (with relative accessories), circuit-breakers (modular, moulded-case and air) and distribution systems and to respect the selection criteria and assembly instructions for the various components.

GENERAL  
STANDARDS AND  
CHARACTERISTICS

VERIFYING THE  
OVERTEMPERATURES

PROTECTION AGAINST  
SHORT-CIRCUIT AND  
ELECTRIC SHOCKS

PRACTICAL INDICATIONS  
CERTIFICATION AND  
CONSTRUCTION

CERTIFICATES

DECLARATION OF  
CONFORMITY

## ▶ 11 Guide to certification according to the IEC 60439-1 Standard

11.2 Type tests and checks

### 11.2 Type tests and checks

Verifying the overtemperature limits

Chapter 7 is dedicated to verifying the overtemperature limits.

It must be remembered that, from the point of view of verifying the overtemperature limits, it is possible to:

Certify the switchgear as **TTA** when there are the following two conditions

- among the configurations indicated in paragraph 7.4 there is a similar one which, compared with the switchgear to be constructed, has variants (or deviations) which do not change the performances in a crucial way
- as indicated in paragraph 7.3, the Pr total power dissipated by the switchgear to be constructed is less than the Pp total power dissipated by the tested switchgear.

Certify the switchgear as **PTTA** when the following two conditions exist

- among the configurations indicated in paragraph 7.4 there is a similar one which, compared with the switchgear to be constructed, has variants (or deviations) which do not change the performances in a crucial way
- the Pr total power dissipated by the switchgear to be constructed is higher than the Pp total power dissipated by the tested switchgear, but verification of the overtemperature illustrated in paragraph 7.3 leads to a positive result.

Certify the switchgear as **PTTA** when there are the following two conditions

- there is not a similar one among the configurations indicated in paragraph 7.4.
- calculation of the total power dissipated by the apparatus, compared with the power which can be dissipated by the structure (Distribution Switchgear General Catalogue), leads to an overtemperature which is acceptable for the electric circuits and devices inside the switchgear, operating at the normal service current.

### Checking the dielectric properties

As specified by the Standard, carrying out this type test is not required on parts of the switchgear which have already undergone a type test conforming to the corresponding Standards, if the dielectric strength is not jeopardised during assembly.

With regard to ArTu Switchgear, the dielectric properties are as follows:

	Wall-mounted ArTu L D=200mm	Floor-standing ArTu L D=250mm	Wall-mounted ArTu M D=150/200mm	Floor-standing ArTu M ArTu K D=250mm	ArTu K
Rated service voltage:	up to 690V AC	up to 690V AC	up to 690V AC	up to 690V AC	up to 1000V AC
Rated insulation voltage:	up to 1000V AC	up to 1000V AC	up to 1000V AC	up to 1000V AC	up to 1000V AC
Rated impulse withstand voltage:	6 kV	8 kV	6 kV	8 kV	8 kV

These properties are to be considered already verified as long as the assembly instructions are followed correctly.

## 11 Guide to certification according to the IEC 60439-1 Standard

11.2 Type tests and checks

### Checking short-circuit withstand

Chapter 8 of this guide is dedicated to the short-circuit withstand.

As specified by the Standard, it is not necessary to verify the short-circuit withstand:

1. when the check turns out not to be necessary from the flow diagrams in paragraph 8.1
2. for the switchgear auxiliary circuits foreseen for connection to transformers whose rated power does not exceed 10 kVA with a rated secondary voltage which is not less than 110 V, or does not exceed 1.6 kVA with a rated secondary voltage of less than 110 V, and whose short-circuit voltage in both cases is not less than 4%
3. for all the different parts of the equipment which have already undergone type tests valid for the existing layout conditions.

In particular, for the distribution systems (indicated in the Distribution Switchgear General Catalogue), the short-circuit withstand is verified by a positive result from the flow diagrams in paragraph 8.3 and by carrying out the assembly instructions correctly.

For the different types of switchgear, the following characteristics are to be considered verified

	ArTu L Wall-mounted D=200mm	ArTu L Floor-mounted D=250mm	ArTu M Wall-mounted D=150/200mm	ArTu M /ArTu K Floor-mounted D=250mm	ArTu K
Rated short-time short-circuit current: phase-phase	25 kA (1s)	35 kA (1s)	25 kA (1s)	35 kA (1s)	105kA (1s) 50kA(3s)
phase-neutral	9 kA (1s)	21 kA (1s)	9kA (1s)	21 kA (1s)	60 kA (1s)
Rated max. peak short-circuit current	52.5kA	73kA	52.5kA	73kA	254kA

### Checking the short-circuit withstand of the protection circuit

<b>Verifying effective connection of the switchgear exposed with conductive parts and the protection circuit</b>	Respecting the assembly indications of the metal components, the effective electrical continuity between the exposed conductive parts is verified, negligible resistance values.				
<b>Short-circuit withstand of the protection circuit: phase-earthing busbar</b>	Respecting the assembly indications and the indications on page 52 of this guide, the short-circuit withstand of the protection circuit is verified.				
<b>Maximum phase-earthing busbar short-circuit withstand for structure</b>	ArTu L Wall-mounted D=200mm	ArTu L Floor-mounted D=250mm	ArTu M Wall-mounted D=150/200mm	ArTu M /ArTu K Floor-mounted D=250mm	ArTu K
	9 kA (1s)	15 kA (1s)	9 kA (1s)	15 kA (1s)	60 kA (1s)

### Checking insulation distances

By respecting the assembly and erection instructions for the metal structures and ABB SACE circuit-breakers, the insulation distances are guaranteed.

### Checking mechanical operation

By following the assembly instructions for the metal structures and ABB SACE circuit-breakers, mechanical operation is ensured.

### Checking degree of protection

By following the assembly instructions for the metal structures and ABB SACE circuit-breakers, the following degrees of protection are ensured:

	ArTu L Wall-mounted D=200mm	ArTu L Floor-mounted D=250mm	ArTu M Wall-mounted D=150/200mm	ArTu M /ArTu K Floor-mounted D=250mm	ArTu K
<b>Without door</b>	IP31	IP31	-	IP31	IP31
<b>With door and ventilated side panels</b>	-	-	-	-	IP41
<b>Without door with kit IP41</b>	-	-	-	-	IP41
<b>With door</b>	IP43	IP43	IP65	IP65	IP65

GENERAL  
STANDARDS AND  
CHARACTERISTICS

VERIFYING THE  
OVERTEMPÉRATURES

PROTECTION AGAINST  
SHORT-CIRCUIT AND  
ELECTRIC SHOCKS

PRACTICAL INDICATIONS  
CERTIFICATION AND  
CONSTRUCTION

CERTIFICATES

DECLARATION OF  
CONFORMITY



## ► 11 Guide to certification according to the IEC 60439-1 Standard

11.3 Individual tests and checks (switchgear testing)

### 11.3 Individual tests and checks (switchgear testing)

The individual tests, sometimes called switchgear testing, prescribed and defined in the IEC 60439-1 Standard under art. 8.1.2, must be carried out on all the switchgear under the responsibility of the assembler and at completion of switchgear assembly and cabling. The aim of these tests is to check for any defects concerning materials or fabrication defects of the components and/or of the switchgear assembly. The good outcome of the individual tests allows a favourable test report to be drawn up (test record).

We give a procedure for verifying the individual tests which can provide qualified personnel with instructions for carrying out the tests correctly.

#### Procedures and methods for carrying out the individual tests

The manufacturer of the switchgear can formalize a procedure for what concerns:

- the test conditions (trained personnel, area of the workshop destined for testing, etc.) and the safety measures;
- reference documents (technical dossiers, assembly instructions, technical standards, etc.);
- identification of the material and visual inspections, mechanical and electric checks;
- dielectric tests;
- checking the means of protection and checking continuity of the protection circuit;
- measurement of the insulation resistance for the PTTA switchgear, as an alternative to the dielectric test;
- final documentation (test report).

In any case it is important to underline that, although the individual tests are normally carried out in the switchgear manufacturer's or the switchgear builder/assembler's workshop, the installer is not exempt from the obligation of making sure that the switchgear has not undergone any damage or modifications after transport and installation such as to no longer conform to the requirements already verified during the individual tests.

#### Test conditions and safety measures

It is recommended that the switchgear ready to undergo the individual tests inside the workshop be positioned in separate areas where only qualified personnel have free access. Should this not be possible, for example for reasons of space, the area for the tests must be marked off by barriers, notices or visible barriers.

Of course the checks can only start when assembly has already been completed.

During the check of the dielectric properties, for example during the applied voltage test, the insulating gloves provided must be worn and the special pistol type push rods with retractile tips must be used. The operator's body and arms should be suitably protected, except when the voltage is applied at an adequately safe distance.

Below are some rules for carrying out the individual tests in safety.

*Before the tests:*

- position the switchgear in a suitable area;
- correctly install the protection barriers;
- correctly make the switchgear power supply connections (earth and power supply);
- make the other connections using the same principles (interconnection between exposed conductive parts and earth connections);
- make sure that the safety devices used are perfectly operational; (e.g. the emergency pushbutton, the flashing danger signalling devices, etc.);
- make sure that there are no unauthorised people inside the area reserved for the tests.

*During the tests:*

- in the case of even temporary suspension of the tests, it is necessary to de-energise the equipment being tested;
- for the energised checks or electric measurements, it is necessary for the person in charge of carrying them out to be aware of the danger, to make sure the measuring instruments used comply with the safety requirements and that suitable protection devices are used (for example, insulating gloves, etc.);
- the cables or electric instruments must not be left outside the marked off test area.

## ▶ 11 Guide to certification according to the IEC 60439-1 Standard

11.3 Individual tests and checks (switchgear testing)

### Reference documents

The elements specific to the switchgear to be tested, to which the tester can duly refer, are the diagrams (single-line, functional, mimic diagrams, etc.), the drawings (front of switchgear, overall dimensions, etc.) and the particular specifications.

Apart from the latest edition of the technical standards the switchgear is declared to conform to, the checker can also refer to the IEC 60529 Standards (degrees of protection of the housings), to the EN 60664-1 Standard (rules for coordination of the insulation devices), etc.

### Identification of the material and controls

This represents the first individual test foreseen by the IEC 60439-1 Standard, par. 8.3.1. It includes the following checks.

#### *Visual inspections*

These are carried out visually, taking into account:

- a) conformity of the switchgear in relation to the diagrams, nomenclature and drawings and by means of the number and type of cubicles, the number and characteristics of the apparatus, the cross-section of the conductors and the presence of identification marks on the cables and apparatus (initials, nameplate wording, etc.);
- b) the presence of components which allow the degree of protection to be guaranteed (roofs, gaskets) and the absence of any defects on the enclosure (cuts, or drilling which would risk jeopardising the degree of protection);
- c) correspondence with the specific prescriptions, where requested by the assembly note, such as:
  - coating or treatment of the busbars (resin finish, silver-plating, etc.);
  - the type of cable (flameproof, ecological, etc.);
  - the loose completion material;
  - the painting check (colour, thickness, etc.).

#### *Mechanical checks*

These must be carried out according to the reference documents, with reference to the following checks:

- correct assembly of the equipment (arrangement of the connections and, at random, correct tightening of the connections);
- positioning and tightening of the nuts and bolts;
- mechanical locks and controls (racking-in locking devices, mechanical interlocks, key interlocks and manual operating mechanisms for traverse of the circuit-breakers and for operation of the switch disconnectors using the operating levers and accessories provided with the switchgear);
- closure and possible locks of the doors and any adherence of the dust-proofing gaskets on the switchgear structure.

#### *Electrical checks*

The functional tests consist of checking correct operation of all the circuits (electric and electromechanical) simulating, as far as possible, the various service conditions of the switchgear. For example, the tests on the current and voltage circuits can be carried out by supplying the secondary CT and VT circuits, without necessarily disconnecting the CT from the circuit.

The electrical controls may include checking correct operation of the circuits and apparatus and in particular:

- control, signalling, alarm, trip and reclosing circuits;
- lighting and heating circuits, where these exist;
- protection and measuring circuits (overcurrent, overvoltage, earth, residual current releases, contactors, ammeters, voltmeters, etc.);
- terminals and contacts available in the terminal box;
- insulation surveillance devices (the insulation distances and the escape lines at the level of the connections and adaptations made in the workshop).

Apart from the normal mechanical tools used for assembly, electrical instruments are required to carry out the checks. Periodic calibration of the latter is recommended in order to obtain reliable results.

The instruments normally used are:

- a tester or multimeter;
- the test bench (in AC and in DC) which supplies the switchgear during the energised operating test;
- the dynamometric spanner (to check that the correct tightening torques have been applied on the connections) and various other tools.

## 11 Guide to certification according to the IEC 60439-1 Standard

11.3 Individual tests and checks (switchgear testing)

### Applied voltage test (required for TTA switchgear)

The dielectric tests serve to check the insulation distances, the soundness of the insulating materials and correct execution of the connections of the equipment being tested.

If an Uimp is not declared, a test voltage at power frequency is applied for one second between the phases, interconnected with each other, and the frame of the switchgear connected to earth.

Below, the test voltage values according to the rated insulation voltage are given.

For the main circuits and the auxiliary circuits connected directly to the mains network:

Rated insulation voltage $U_i$ (between phases)				Dielectric test voltage in AC	
V				V eff. r.m.s.	
		$U_i \leq$	60		1000
60	<	$U_i \leq$	300		2000
300	<	$U_i \leq$	690		2500
690	<	$U_i \leq$	800		3000
800	<	$U_i \leq$	1000		3500
1000	<	$U_i \leq$	1500*		3500

\* Only for DC

For the auxiliary circuits not connected directly to the mains network:

Rated insulation voltage $U_i$ (between phases)				Dielectric test voltage in AC	
V				V eff. r.m.s.	
		$U_i \leq$	12		250
12	<	$U_i \leq$	60		500
		$U_i >$	60		$2 U_i + 1000$ con un minimo di 1500

All the protection and operating apparatus must be closed, or the test voltage must be applied successively to all parts of the circuit.

A generator of voltage at power frequency (dielectrometer) can be used for this test.

The test is passed if there are neither perforations nor surface discharges during application of the voltage.

All the apparatus which consumes current and for which application of the test voltages would cause damage must be disconnected (windings, measuring instruments, electronic residual current circuit-breakers, etc.).

The following indications are valid for the ABB SACE devices in particular:

#### Residual current

devices	residual	operation to be carried out
circuit-breaker	current release	
$T_{max}$ RC222	RC221	Turn the special selector on the front of the
Isomax, Emax	RCQ	It must be disconnected manually

#### Electronic releases

circuit-breaker	type of release	operation to be carried out
$T_{max}$ PR222	PR221	No operation
Isomax PR212	PR211	No operation
Emax	PR111	Disconnect, if the cabling relative to T1, T2, T3 and T4 is present
Fixed version	PR112	Disconnect, if the cabling relative to: K1, K2, K3, K4, K5, K6, K7, K8, K9, K10, K11, K12-T7, K13-T8, K14, K15-T9, K16, T10, D13-K17, D14-K18, 12, 14, 38, W1, W2, CC1, W3, W4, CC2, C1, C3-K19, C11, C13-K20, T1, T2, T3, T4, T5, T6.
Emax	PR113	
Fixed version		
Emax	PR111	
Withdraw. version	PR112	Take the circuit-breaker to the racked-out position
	PR113	

Furthermore, all the accessories of the circuit-breakers connected directly to the mains network must be disconnected (undervoltage release, opening coils, motor operators, etc.).

## ▶ 11 Guide to certification according to the IEC 60439-1 Standard

11.3 Individual tests and checks (switchgear testing)

### Checking the means of protection and continuity of the protection circuit

The individual test, foreseen by IEC 60439-1 in 8.3.3, requires verification of continuity of the protection circuit.

Good realization of the protection circuit is ascertained:

- visually (e.g. the presence of devices which guarantee the contact for purposes of continuity of the earthing conductor, etc.);
- mechanically (by checking tightness of connections, taking samples);
- electrically (by checking circuit continuity).

The tools used are a tester and a dynamometric spanner.

### Checking the insulation resistance

In the case of PTTA switchgear, a measurement of the insulation resistance is made in conformity with the IEC 60439-1 art. 8.3.4 Standard, as an alternative to the applied voltage test.

The test is done by applying a voltage of 500 V between the circuits and the exposed conductive part and the result is positive when, for each circuit tested, the insulation resistance is higher than 1000 W/V, referred to the rated voltage to earth for each circuit.

Again in this case, the equipment which consumes current must be disconnected.

Resistance measuring apparatus (mega ohmmeter or megger) can be used for the test.

### Final documentation and completion of the tests

It is a good idea to use the analytic forms where all the checks appear, in detail as well. This way, the various items can be struck off one at a time to make sure that all the operations required have been carried out.

An example of a table summarising the checks foreseen for switchgear subjected to individual tests is given in annex A.

On completion, it is advisable to make out a test report where the tests specified by the Standard are indicated and the result obtained for each of them.

An example of a test report is given in annex A.

## ▶ 12 Example of construction of ArTu switchgear

12.1 Single-line diagram

This paragraph has the aim of helping the panel builder and the designer in constructing ABB SACE ArTu switchgear.

To do this, you start from the single-line diagram of a plant to reach, by means of selection of the components, construction of the switchgear and the relative declaration of conformity according to 60439-1.

Characteristics of the switchgear, taken from the specification, are:

- unsegregated switchgear
- IP65
- exposed wall-mounted

### 12.1 Single-line diagram

Let us suppose that realization of main distribution switchgear is required, placed immediately to the load side of a 2000kVA MV/LV transformer. Three 850A feeders leave this switchgear which will go to supply other pieces of distribution switchgear which, however, we shall not deal with.

For reasons of selectivity with the switchgear circuit-breakers on the load side, use of air type circuit-breakers is selected, branched from the busbars.

The main distribution busbar short-circuit current is 43.6 kA

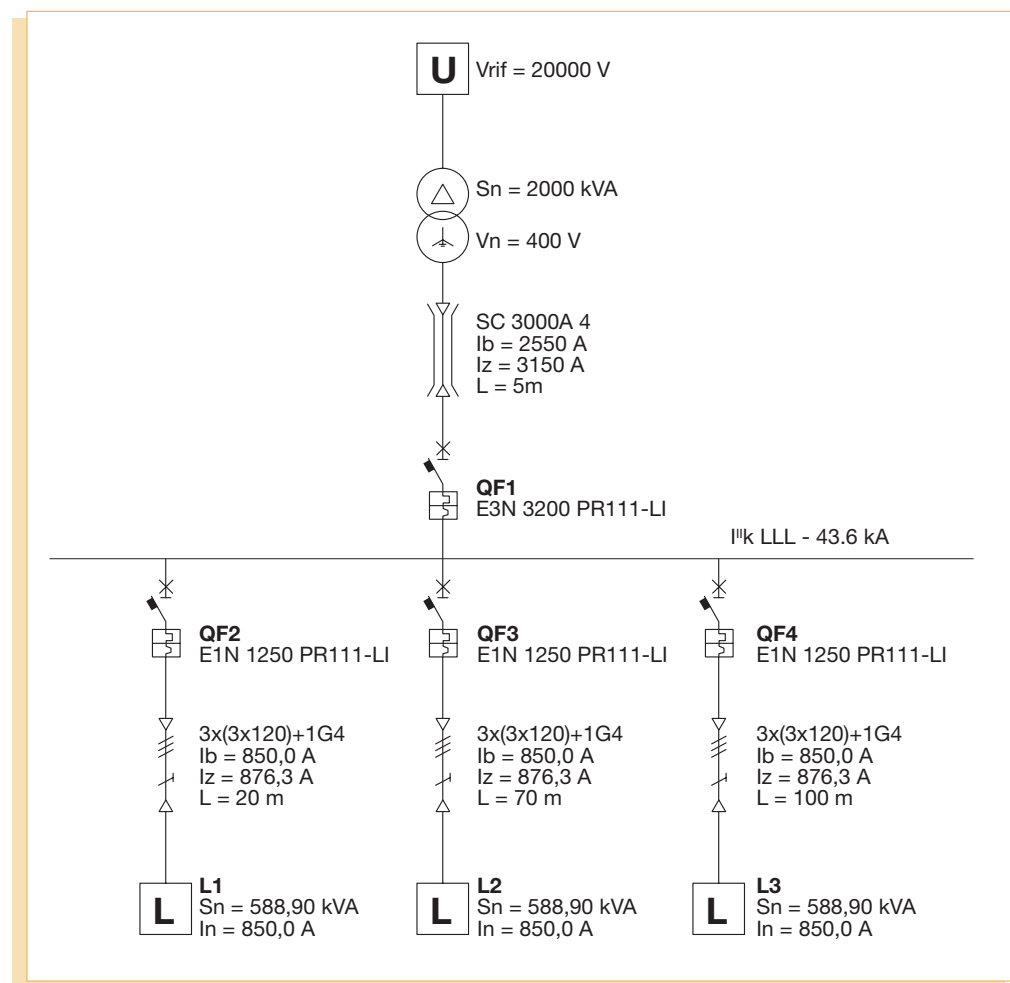

## ► 12 Example of construction of ArTu switchgear

12.2 Selection of the circuit-breakers and ducts outside the switchgear  
12.3 Front of switchgear, distribution system and metal structure

### 12.2 Selection of the circuit-breakers and ducts outside the switchgear

#### Circuit-breakers

As shown on the single-line diagram, the circuit-breakers selected are:

1 Emax E3N3200 PR111-LSI In 3200 (main switchgear circuit-breaker)

3 Emax E1N1250 PR111-LSI In 1250 (circuit-breakers for the three outgoing feeders)

#### Ducts

Incoming, from the transformer there is the following:

1 Bus duct with  $I_z = 3150$  A;  $L = 5$  m

Outgoing from the switchgear, hypothesising overhead laying on perforated trays, there is:

1 cable with  $L = 20$  m       $3 \times (3 \times 120)$   $I_z = 876,3$  A

1 cable with  $L = 70$  m       $3 \times (3 \times 120)$   $I_z = 876,3$  A

1 cable with  $L = 100$  m      $3 \times (3 \times 120)$   $I_z = 876,3$  A

### 12.3 Front of switchgear, distribution system and metal structure

With regard to positioning the apparatus, it was decided to house the main circuit-breaker in one column, and the three outgoing feeders in another.

Since the power supply comes from below, it was decided to position the QF1 at the bottom.

The switchgear is of the unsegregated type.

A possible layout for the busbars and circuit-breakers is given in the following figure

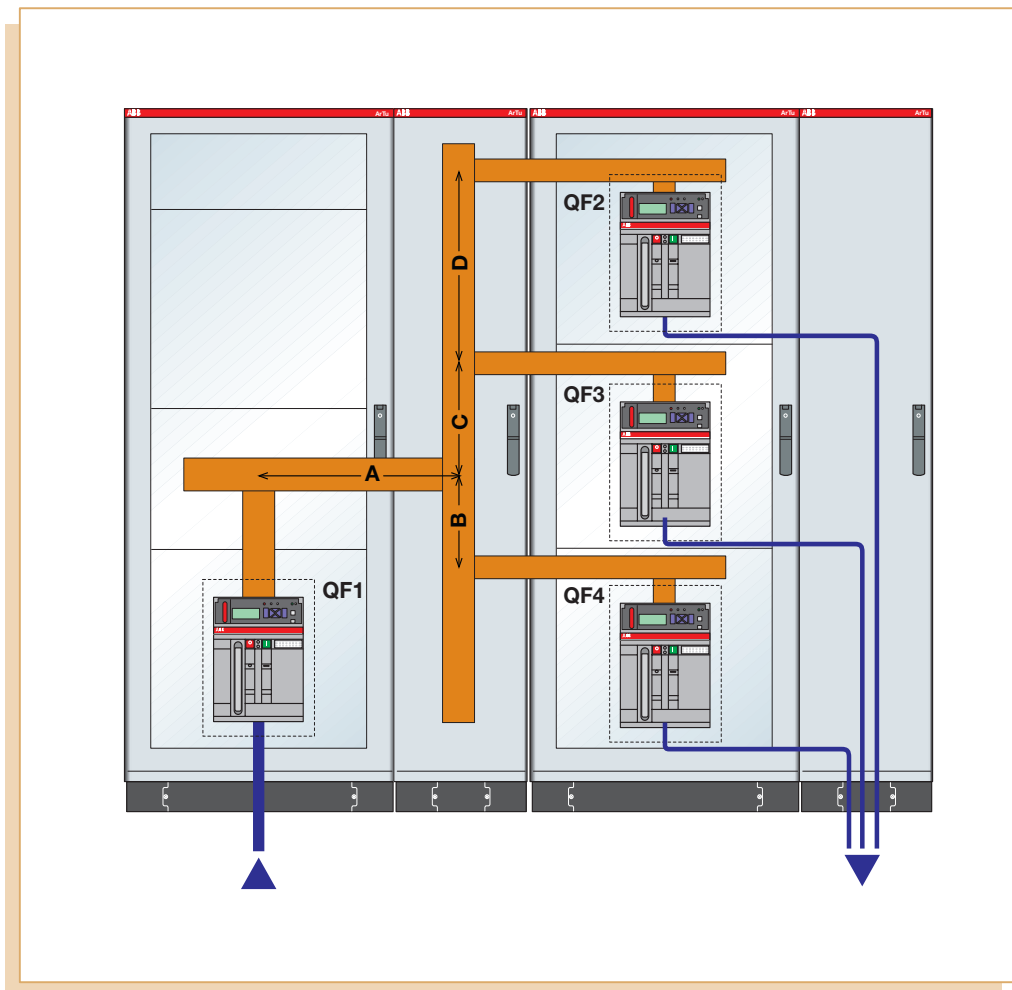

## 12 Example of construction of ArTu switchgear

12.3 Front of switchgear, distribution system and metal structure

### Distribution system

With regard to the busbars inside the switchgear, as an initial approximation, they are selected according to the size of the circuit-breaker:

**Main distribution busbars** (QF1 circuit-breaker)  
(From the Distribution Switchgear General Catalogue)

**BA2000**  $I_n=3200$  A (IP65)  $I_{cw}$  max =100 kA

To reach an  $I_{cw}$  suitable for the short-circuit value of the plant, the following must be positioned:

4 PB3201 busbar holders at a maximum distance of 550mm ( $I_{cw}$  =35 kA)

Since there are non-current limiting air circuit-breakers, the  $I_{cw}$  of the distribution system must be higher than the prospective  $I_{cc}$  at the busbars.

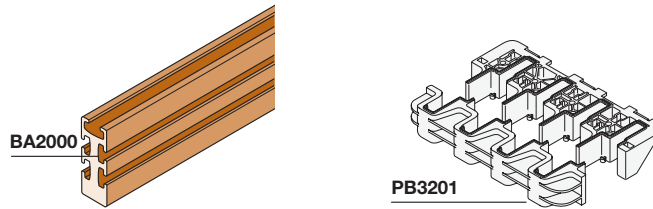

**Branch busbars of the circuit-breakers** (QF2, QF3 and QF4 circuit-breakers)  
(From the Distribution Switchgear General Catalogue)

**BA1250**  $I_n= 1250$  A (IP65)  $I_{cw}$  max = 75 kA

To reach an  $I_{cw}$  suitable for the short-circuit value of the plant, the following must be positioned:

2 **PB1601** busbar holders at a maximum distance of 550mm ( $I_{cw}$  =35 kA)

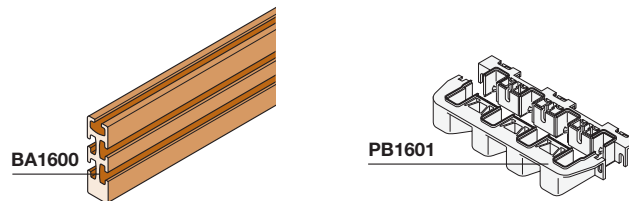

**Joining pieces between circuit-breakers and busbars** (QF2, QF3 and QF4 circuit-breakers).  
The Emax Technical Catalogue gives the cross-sections of the busbars for connection of the circuit-breakers:

**E3N32** 3200 A Cross-section 3x(100x10)

**E1N12** 1250 A Cross-section 1x(80x10)

Moreover, according to the terminals, the maximum anchoring distance of the first anchor plate shown on page 56 of this guide must be respected.

### Joints for busbars

As indicated in the "Distribution Switchgear General Catalogue" the following joints are necessary:

Joining 3200 busbar to 3200 busbar, T joint,  
Joining of 3200 busbar to 1250 busbar, 1250,

**AD1073**

**AD1078**

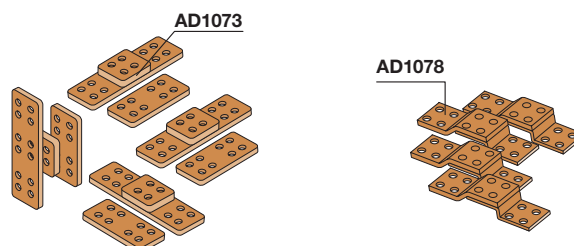

## 12 Example of construction of ArTu switchgear

12.3 Front of switchgear, distribution system and metal structure

### Earthing busbar

As indicated on page 52 of this guide, the earthing busbar must have a minimum cross-section of  $\frac{1}{4}$  of the cross-section of the main busbars. A 50x10 busbar is therefore selected

### Metal Structure

With regard to the structure, an ArTu K series switchgear with door (IP 65) is used. To be able to house the circuit-breakers, the vertical busbar system, and the outgoing cables, the following are used:  
2 columns for the circuit-breakers  
2 cable containers, one for the busbar system and one for the outgoing cables.

For correct selection of the structure, it is advisable to consult the “Distribution Switchgear General Catalogue” where:

- to house Emax E1-E2-E3 circuit-breakers, switchgear with 800mm depth, 600mm width and a **KE3215** installation kit are required
- The cable container selected obviously has 800mm depth and 300mm width.

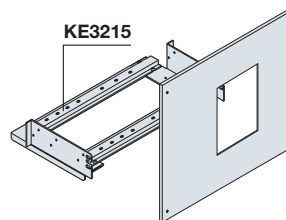

In the Distribution Switchgear General Catalogue, the fixing crosspieces for the busbars with shaped section can be found:

For the horizontal 3200 A busbars (**BA2000**), the type of installation selected is number 5, so the correct selection is two **TV6221** and one **TV8011** components.

For the vertical 3200 A busbars (**B2000**) the type of installation selected is number 2, so the correct selection is the **TV8101** component

For the horizontal 1250 A busbars (**BA1250**) the type of installation selected is number 5, so the correct selection is two **TV6221** and one **TV8011** components.

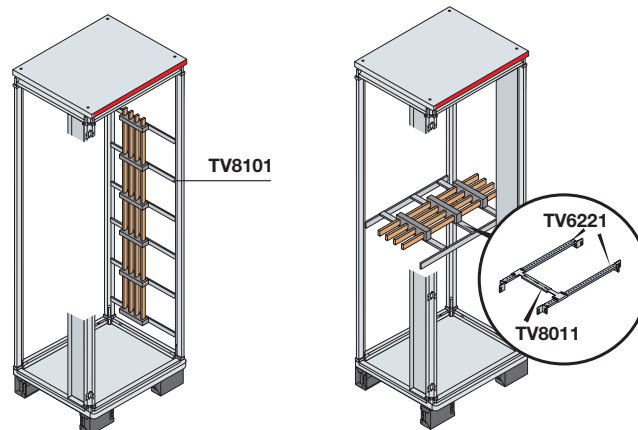

As specified in the Distribution Switchgear General Catalogue, the structure must be completed with the side-by-side kit (**AD1014**).

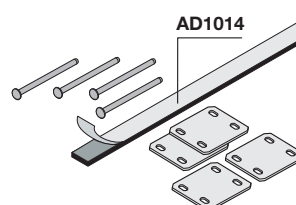



## ► 12 Example of construction of ArTu switchgear

12.4 Conformity with the IEC 60439-1 Standard

### 12.4 Conformity with the IEC 60439-1 Standard

It is necessary to check conformity of the switchgear with the IEC 60439-1 Standard. Taking chapter 11 as the reference, the checks are analysed.

#### Thermal verification of the switchgear

Going to analyse the configurations given in paragraph 7.4, it can be seen that the one on page 36, i.e. Test N° 7, is similar to the configuration to be constructed:

- dimensions of the switchgear,
- type and number of pieces of equipment,
- degree of protection,
- form of segregation,
- value of the currents in the different pieces of apparatus during the test,
- method of installation (exposed, wall-mounted, covered on one side, etc.).

The most obvious difference is found in the position of the main circuit-breaker.

In the tested switchgear this is in the top part of the switchgear, whereas in the switchgear to be constructed, it is in the bottom part. However, as there is no other apparatus inside this column and having positioned the circuit-breaker in a cooler area than that of the tested switchgear, it can be considered that this variant does not change the performances of the switchgear in a crucial way (still from the thermal point of view).

Now we shall pass on to calculation of the power dissipated inside the switchgear.

Circuit-breaker	Type	In	Current	Power
QF1	E3 3200	3200	2550	210 (x1,3)
QF2	E2 1250	1250	850	33 (x1,3)
QF3	E2 1250	1250	850	33 (x1,3)
QF4	E2 1250	1250	850	33 (x1,3)
<b>Total power dissipated by the circuit-breakers</b>				<b>402 W</b>
<b>Busbars</b>		Lenght		
<b>A (BA2000)</b>	3x100x10	0,8	2550	134 W
<b>B (BA2000)</b>	3x100x10	0,3	850	5,6 W
<b>C (BA2000)</b>	3x100x10	0,3	1700	23 W
<b>D (BA2000)</b>	3x100x10	0,6	850	11 W
<b>E (BA1250)</b>	120x10	0,36	850	17 W
<b>F (BA1250)</b>	120x10	0,36	850	17 W
<b>G (BA1250)</b>	120x10	0,36	850	17 W
<b>Total power dissipated by the busbars</b>				<b>225 W</b>
<b>Cable</b>	Cross-section	Lenght	Current	Power
QF1	SC3000	around nil	2550	0 W
QF2	3x120	1700	850	232 W
QF3	3x120	1200	850	164 W
QF4	3x120	around nil	850	0 W
<b>Total power dissipated by the cables</b>				<b>396 W</b>
<b>TOTALE POWER DISSIPATED</b>				<b>1023 W</b>

Since the total power dissipated inside the switchgear to be constructed is less than the total power dissipated in the tested switchgear (1385W), the overtemperature limits have been verified.

## ▶ 12 Example of construction of ArTu switchgear

12.4 Conformity with the CEI EN 60439-1 Standard

### Checking the dielectric properties

Dielectric properties of the switchgear

Rated service voltage	$U_e = 400 \text{ V}$
Insulation voltage	$U_i = 1000 \text{ V}$
Rated impulse withstand voltage	$U_{imp} = 8 \text{ kV}$

These properties are to be considered already verified as long as the assembly instructions are followed correctly.

### Checking the short-circuit withstand

With selections made for the busbars and circuit-breakers, and following the assembly instructions correctly, the short-circuit withstand is verified for a value of  $I_{cw}$  equal to:

**$I_{cw} = 35 \text{ kA}$**

### Checking short-circuit withstand of the protection circuit

By respecting the assembly indications for the metal components, effective electrical continuity between the exposed conductive parts, with negligible resistance values is verified.

Having selected the cross-section of the earthing busbar as indicated on page 52, the protection circuit short-circuit withstand is verified.

### Checking the insulation distances

By respecting the assembly and erection instructions of the metal structures and of the ABB SACE circuit-breakers, the insulation distances are guaranteed.

### Checking mechanical operation

Following the assembly instructions of the metal structures and of the ABB SACE circuit-breakers, mechanical operation is verified.

### Checking the degree of protection

Following the assembly instructions of the metal structures and of the ABB SACE circuit-breakers, the following degree of protection is verified:

**IP65**

# Annex A: LOVAG ACAE certificates

GENERAL STANDARDS AND CHARACTERISTICS

VERIFYING THE OVERTEMPERATURES

PROTECTION AGAINST SHORT-CIRCUIT AND ELECTRIC SHOCKS

PRACTICAL INDICATIONS CERTIFICATION AND CONSTRUCTION

CERTIFICATES

DECLARATION OF CONFORMITY

**ACA E** ASSOCIAZIONE PER LA CERTIFICAZIONE DELLE APPARECCHIATURE ELETTRICHE  
**LOVAG**

V.le delle Brigate Partigiane 625 - 16129 - GENOVA (Italy)  
 tel. +39 0565197 fax. +39 05648607 e-mail: accae@tin.it

### Certificate of Conformity

LOVAG-Certificate No. IT 99.025  
 page 1 of 2

**Apparatus**  
 Low voltage switchgear and controlgear assembly - 3 phases + neutral - 400 V (U<sub>n</sub>) - 690 V (U<sub>i</sub>) - frequency 50 Hz

**Designation**  
**ARTU K**

**Manufacturer or responsible vendor**  
**ABB TURATI SpA - Via Italia 38/42 - 23846 Garbagnate Monastero (LC) (Italy)**

**Tested for:** ABB TURATI SpA - Via Italia 38/42 - 23846 Garbagnate Monastero (LC) (Italy)

**Tested by:** ACAE Laboratory IA.01

The apparatus, constructed in accordance with the description mentioned in the Test Report listed on this Certificate has been subjected to the series of proving tests in accordance with:  
 IEC 439-1 (1992-11) ed. 3, EN 50439-1 (1994-01)

The results are shown in the Test Report in accordance with LOVAG. The values obtained and the general performance are considered to comply with the above Standard(s) and to justify the characteristic assigned by the manufacturer as stated below.

- Verification of temperature rise-limits ;  
 Rated currents see page 2 of 2 - Outgoing circuits diversity factor = 0,83
- Verification of short-circuit withstand strength
- Verification of the effectiveness of the protective circuit
- Verification of the dielectric properties (declared U<sub>imp</sub> = 6 kV)

See following page 2 of 2

This document includes Report No.: 96.193/T01  
 Issue Date: 1999.02.19

**Responsible Certification Body**

*Francesco Feltrini*  
 Authorized Signature  
 Date 1999.04.01

**ACA E** ASSOCIAZIONE PER LA CERTIFICAZIONE DELLE APPARECCHIATURE ELETTRICHE  
**LOVAG**

### Certificate of Conformity

LOVAG-Certificate No. IT 99.025  
 Page 1 of 2

Circuit	Rated current I <sub>n</sub> [A]	Rated conditional short-circuit current I <sub>cs</sub> [kA]
1.0	1200	50 (N + 30)
1.1	600	50 (N + 30)
1.2	300	50 (N + 30)
1.3	300	50 (N + 30)
1.4	270	50 (N + 30)
1.5	150	50 (N + 30)
1.6	150	50 (N + 30)
1.7	150	50 (N + 30)

The Certificate applies only to the apparatus tested. The responsibility for conformity of any apparatus having the same designation with that tested rests with the manufacturer or responsible vendor.

This certificate has been prepared according to LOVAG (Low Voltage Agreement Group) Objectives and Operating Procedures of mutual recognition. The responsible certification body is a member of LOVAG issues a Certificate of Conformity with the above mentioned Standard(s) following the existence use of LOVAG Test Instructions whenever applicable.

Only integral reproduction of this Certificate or reproductions of this page accompanied by any page(s) on which are stated the tests performed and the assigned rated characteristics of the apparatus tested, are permitted without written permission from the LOVAG Signatory responsible for this Certificate.

For Distribution Bars:  
 - Rated short-time withstand current I<sub>cs</sub> [kA] : 50 (N + 30)  
 - Rated peak withstand current I<sub>ps</sub> [kA] : 100 (N + 30)

**Responsible Certification Body**

*Francesco Feltrini*  
 Authorized Signature  
 Date 1999.04.01

## Annex A: LOVAG ACAE certificates

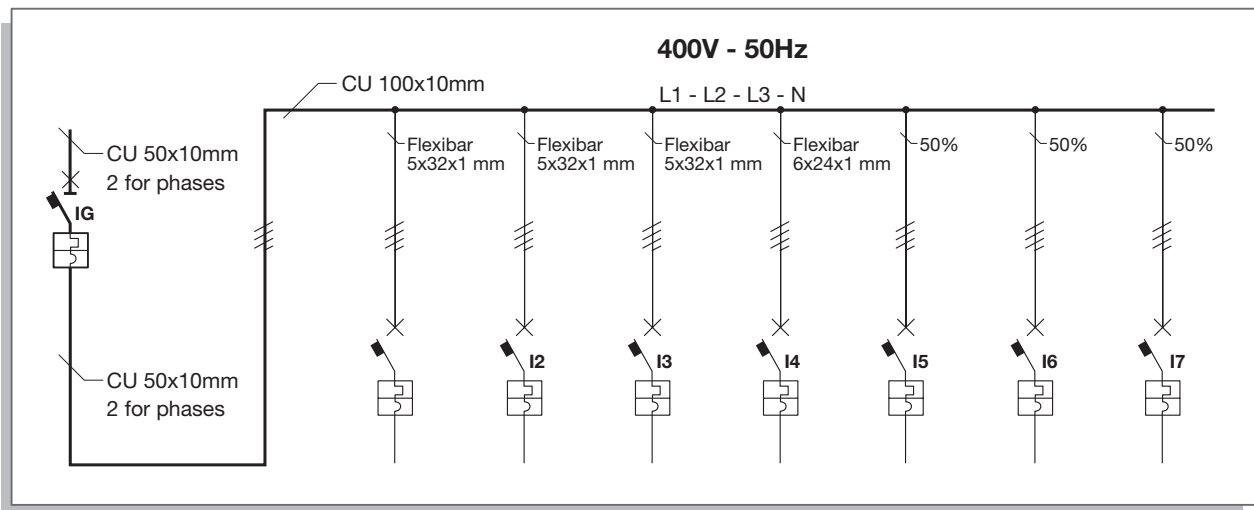
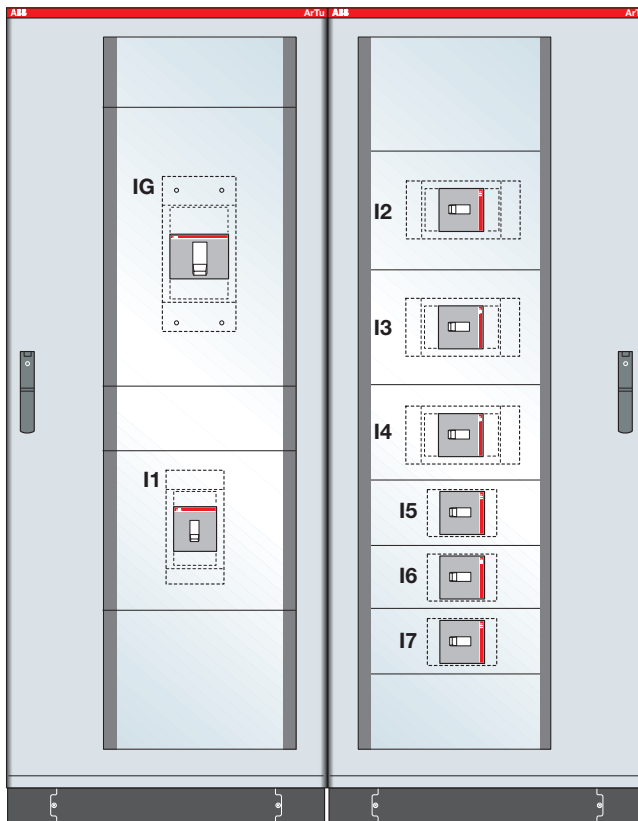

Circuit		IG	I1	I2	I3	I4	I5	I6	I7
Circuit-breaker	Type	Isomax S7 H	Isomax S5 H	Isomax S5 H	Isomax S5 H	Isomax S4 H	Isomax S2 S	Isomax S2 S	Isomax S2 S
or switch discon.	Poles - capacity	4x1600 A	4x400 A	4x400 A	4x400 A	4x250 A	4x125 A	4x125 A	4x125 A

GENERAL  
STANDARDS AND  
CHARACTERISTICS

VERIFYING THE  
OVERTEMPATURES

PROTECTION AGAINST  
SHORT-CIRCUIT AND  
ELECTRIC SHOCKS

PRACTICAL INDICATIONS  
CERTIFICATION AND  
CONSTRUCTION

CERTIFICATES

DECLARATION OF  
CONFORMITY

# Annex A: LOVAG ACAE certificates

GENERAL STANDARDS AND CHARACTERISTICS

VERIFYING THE OVERTEMPERATURES

PROTECTION AGAINST SHORT-CIRCUIT AND ELECTRIC SHOCKS

PRACTICAL INDICATIONS CERTIFICATION AND CONSTRUCTION

CERTIFICATES

DECLARATION OF CONFORMITY

**LOVAG**  
ASSOCIAZIONE PER LA CERTIFICAZIONE DELLE APPARECCHIATURE ELETTRICHE  
Via Tito Livio, 5 - 24123 - BERGAMO (Italy)  
Tel. +39 035 6171244 Fax. +39 035 4534652 e-mail: accaee@lovag.it

## Certificate of Conformity

LOVAG-Certificate No. **IT 01.036**  
page 1 of 2

**Apparatus**  
Low voltage switchgear and controlgear assembly - 3 phases + neutral - 415 V (U<sub>n</sub>) - 690 V (U<sub>e</sub>) - frequency 50 Hz

**Designation**  
**ArTu K**

**Manufacturer or responsible vendor**  
**ABB SACE S.p.A.** Automation and Distribution Boards Division  
- Via Italia, 58 - 23846 Garbagnate Monastero (LC) Italy

**Tested for: ABB SACE S.p.A.** Automation and Distribution Boards Division  
- Via Italia, 58 - 23846 Garbagnate Monastero (LC) Italy

**Tested by: ACAE Laboratory IA.91**  
The apparatus, constructed in accordance with the description mentioned in the Test Report listed on this Certificate has been subjected to the series of proving tests in accordance with IEC 60439-1 (1992-11) ed. 3; EN 60439-1 (1994-01)

The results are shown in the Test Report in accordance with LOVAG. The values obtained and the general performance are considered to comply with the above Standard(s) and to justify the characteristic assigned by the manufacturer as stated below.

- Verification of temperature rise limits:  
Rated diversity factor = 1
- Verification of the dielectric properties (declared U<sub>imp</sub> = 6 kV)
- Verification of short-circuit withstand strength
- Verification of the effectiveness of the protective circuit

This document includes Report No.: 01.044  
Issue Date: 2001.06.07

**Responsible Certification Body**  
*Mauri Merchi*  
Mauri Merchi  
Authorized Signature  
Date: 2001.07.25

**LOVAG**  
ASSOCIAZIONE PER LA CERTIFICAZIONE DELLE APPARECCHIATURE ELETTRICHE  
Via S. Zilio, 5 - 24123 - BERGAMO (Italy)  
Tel. +39 035 6171244 Fax. +39 035 4534652 e-mail: accaee@lovag.it

## Certificate of Conformity

LOVAG-Certificate No. **IT 01.036**  
Page 2 of 2

- Verification of clearance and creepage distances  
- Verification of the degree of protection (IP 54)

**Circuit characteristics**

Circuit	Rated current I <sub>n</sub>	Rated short-time withstand current I <sub>cs</sub> kA
1.0	4000	50
1.10	3200	50
1.1	1600	50

**Responsible Certification Body**  
*Mauri Merchi*  
Mauri Merchi  
Authorized Signature  
Date: 2001.07.25

**LOVAG**  
ASSOCIAZIONE PER LA CERTIFICAZIONE DELLE APPARECCHIATURE ELETTRICHE  
Via S. Zilio, 5 - 24123 - BERGAMO (Italy)  
Tel. +39 035 6171244 Fax. +39 035 4534652 e-mail: accaee@lovag.it

## Certificate of Conformity

LOVAG-Certificate No. **IT 01.036**  
Page 3 of 2

The certificate applies only to the apparatus tested. The responsibility for conformity of any apparatus having the same designation with the tested units with the manufacturer or responsible vendor.

This certificate has been prepared according to LOVAG (Low Voltage Agreement Group) Objectives and Operating Principles of mutual recognition. The responsible certification body as member of LOVAG issues a Certificate of Conformity with the above mentioned Standard(s) following the exclusive use of IEC/EN Test Instructions whenever applicable.

Only integral reproduction of this Certificate or reproductions of this page accompanied by any pages on which are stated the tests performed and the assigned rated characteristics of the apparatus tested, are permitted without written permission from the LOVAG signatory responsible for this Certificate.

Circuit	Rated current I <sub>n</sub>	Rated conditional short-circuit current I <sub>cs</sub> kA
1.2	200	50
1.3	120	50
1.4	50	50
1.5	50	50
1.6	50	50
1.7	50	50
1.8	50	50
1.9	320	50
1.10	200	50
1.11	100	50
1.12	100	50
1.13	100	50
1.14	16	50
1.15	16	50
1.16	800	50
1.17	800	50
1.18	1204	-

**Responsible Certification Body**  
*Mauri Merchi*  
Mauri Merchi  
Authorized Signature  
Date: 2001.07.25

## ► Annex A: LOVAG ACAE certificates

GENERAL STANDARDS AND CHARACTERISTICS

VERIFYING THE OVERTEMPATURES

PROTECTION AGAINST SHORT-CIRCUIT AND ELECTRIC SHOCKS

PRACTICAL INDICATIONS AND CERTIFICATION AND CONSTRUCTION

CERTIFICATES

DECLARATION OF CONFORMITY

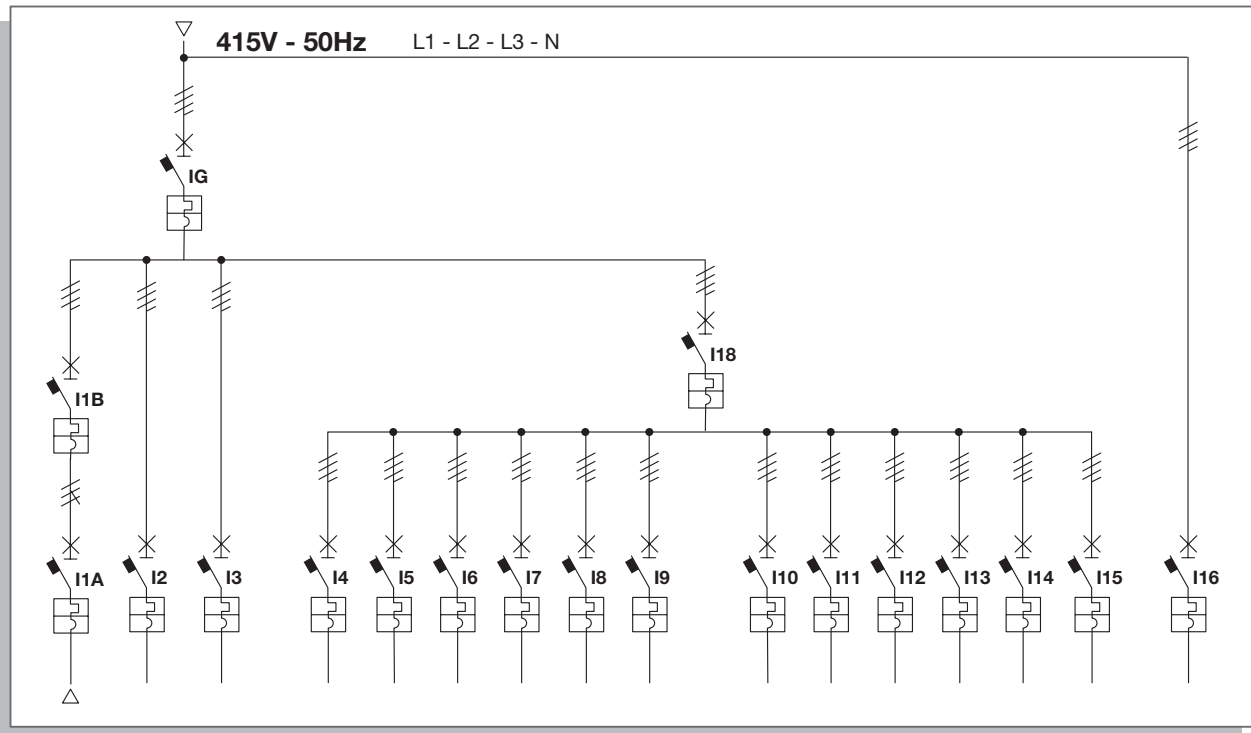
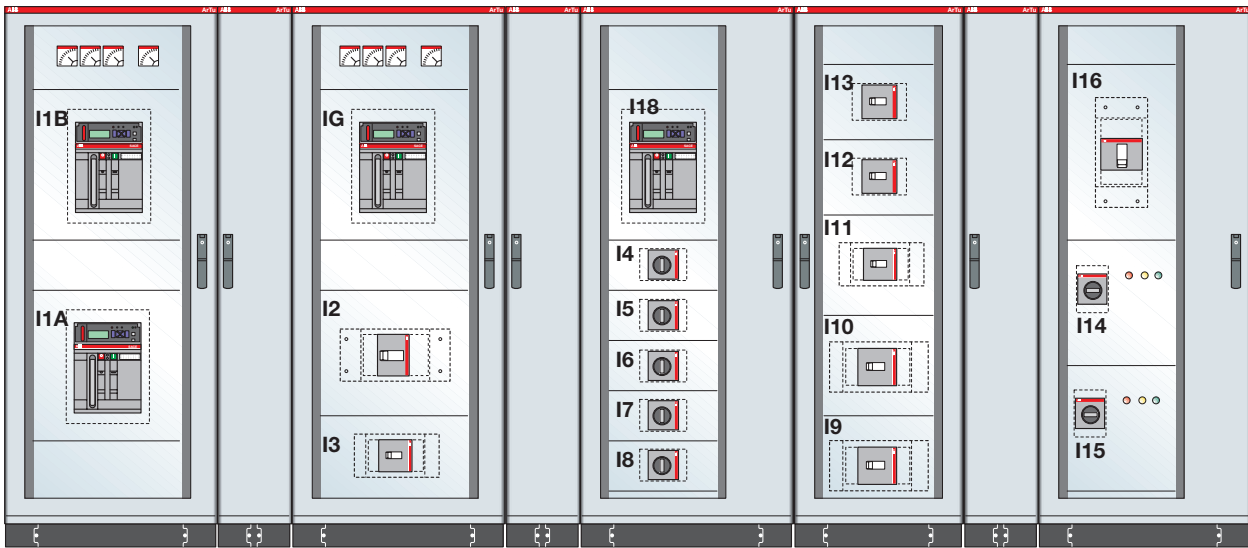

Circuit		IG	I1 A-B	I2	I3	I4 + I8	I9	I10	I11	I12-13	I14-15
Circuit-breaker	Type	Emax E4 H	Emax E3 S	Isomax S7 H	Isomax S5 H	Isomax S2 S	Isomax S6 H	Isomax S6 H	Isomax S5 H	Isomax S3 H	Isomax S2 S
or switch discon.	Poles - capacity	4x4000 A	4x2000 A	4x1600 A	4x400 A	4x160 A	4x800 A	4x630 A	4x400 A	4x250 A	4x160 A

Circuit		I16	I18							
Circuit-breaker	Type	Isomax S7 H	Emax E2 N							
or switch discon.	Poles - capacity	4x1600 A	4x1600 A							

► Annex A: LOVAG ACAE certificates

GENERAL STANDARDS AND CHARACTERISTICS

VERIFYING THE OVERTEMPERATURES

PROTECTION AGAINST SHORT-CIRCUIT AND ELECTRIC SHOCKS

PRACTICAL INDICATIONS CERTIFICATION AND CONSTRUCTION

CERTIFICATES

DECLARATION OF CONFORMITY

**ACAE** ASSOCIAZIONE PER LA CERTIFICAZIONE DELLE ATTIVITÀ DI INGENNERIA ELETTRICA  
Via Tito Livio, 5 - 24123 - BERGAMO (Italy)  
tel. +39 035 4175248 fax. +39 035 4534652 e-mail. accaer@tin.it

**LOVAG**

### Certificate of Conformity

LOVAG-Certificate No. IT 01.037  
page 1 of 3

**Apparatus**  
Low voltage switchgear and controlgear assembly - 3 phases + neutral - 415 V (U<sub>N</sub>) - 690 V (U<sub>e</sub>) - frequency 50 Hz

**Designation**  
ArTu K

**Manufacturer or responsible vendor**  
ABB SACE S.p.A. Automation and Distribution Boards Division  
- Via Italia, 58 - 23846 Garbagnate Monastero (LC) Italy

**Tested for:** ABB SACE S.p.A. Automation and Distribution Boards Division  
- Via Italia, 58 - 23846 Garbagnate Monastero (LC) Italy

**Tested by:** ACAE Laboratory IA.01  
The apparatus, constructed in accordance with the description mentioned in the Test Report listed on this Certificate has been subjected to the series of proving tests in accordance with IEC 60439-1 (1992-11) ed. 3; EN 60439-1 (1994-01)  
The results are shown in the Test Report in accordance to LOVAG. The values obtained and the general performance are considered to comply with the above Standard(s) and to justify the characteristics assigned by the manufacturer as stated below.

- Verification of short-circuit withstand strength
- Verification of the effectiveness of the protective circuit

This document includes Report No.: 01.045  
Issue Date: 2001.06.07

**Responsible Certification Body**

*[Signature]*  
Maurizio  
Authorized Signature  
Date 2001.07.25

**LOVAG**

### Certificate of Conformity

LOVAG-Certificate No. IT 01.037  
Page 2 of 3

**Circuit characteristics:**

Circuit	Rated current I <sub>n</sub>	Rated short-circuit withstand current I <sub>sc</sub>
1-6	4000	65
1-8	5000	65
1-11	6000	65

**Responsible Certification Body**

*[Signature]*  
Maurizio  
Authorized Signature  
Date 2001.07.25

**LOVAG**

### Certificate of Conformity

LOVAG-Certificate No. IT 01.037  
Page 1 of 3

**Circuit characteristics:**

Circuit	Rated current I <sub>n</sub>	Rated conditional short-circuit current I <sub>sc</sub>
1-2	200	65
1-3	320	65
1-4	50	65
1-5	30	65
1-6	50	65
1-7	30	65
1-8	50	65
1-9	320	65
1-10	250	65
1-11	160	65
1-12	100	65
1-13	100	65
1-14	16	65
1-15	16	65
1-16	800	65
1-17	800	65
1-18	1214	-

**Responsible Certification Body**

*[Signature]*  
Maurizio  
Authorized Signature  
Date 2001.07.25

## Annex A: LOVAG ACAE certificates

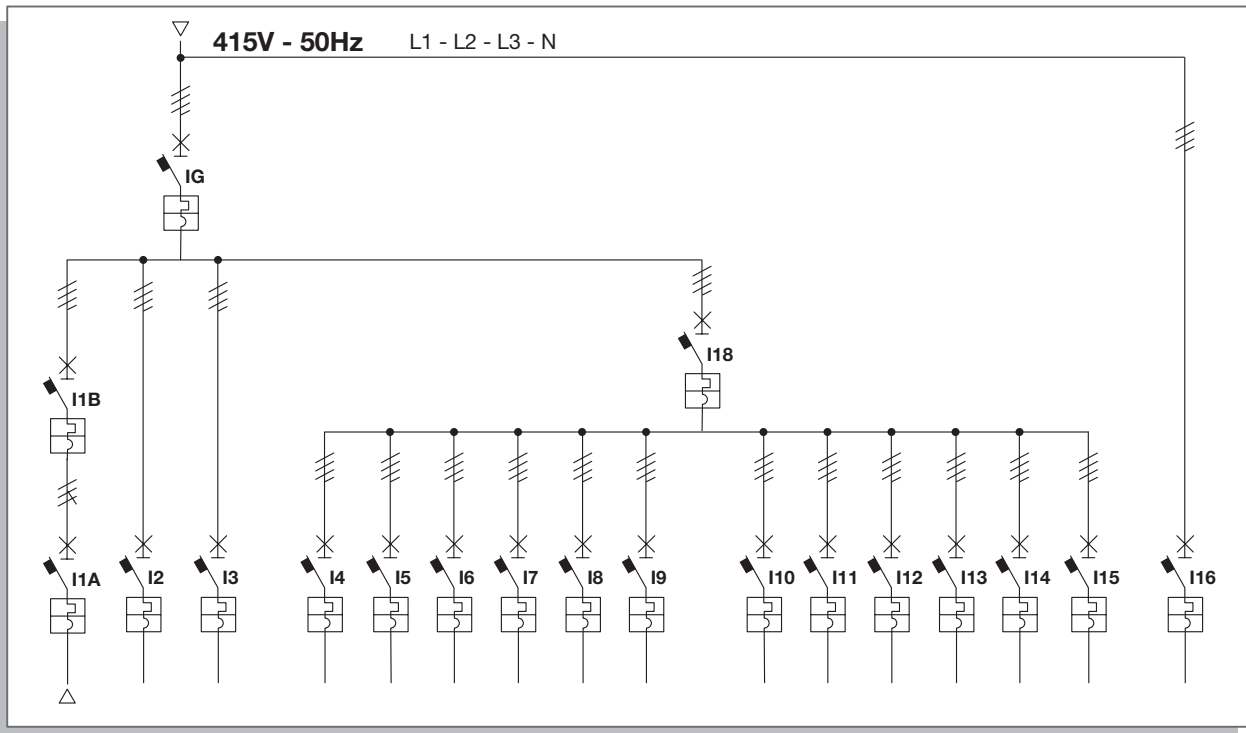
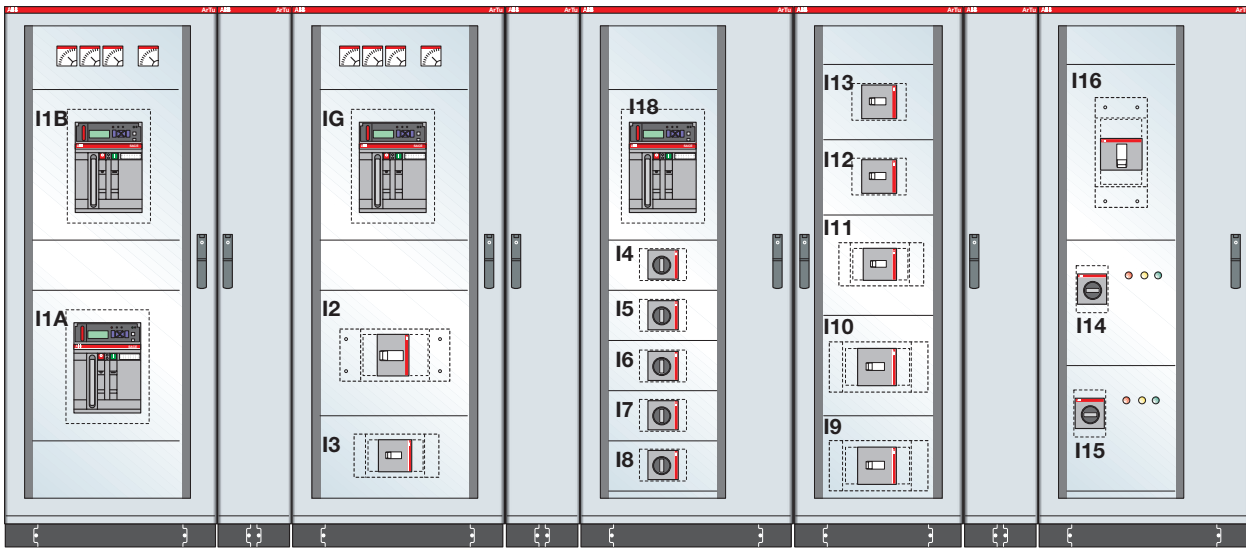

Circuit		IG	I1 A-B	I2	I3	I4 ÷ I8	I9	I10	I11	I12-13	I14-15
Circuit-breaker	Type	Emax E4 H	Emax E3 S	Isomax S7 H	Isomax S5 H	Isomax S2 X	Isomax S6 H	Isomax S6 H	Isomax S5 H	Isomax S3 H	Isomax S2 S
or switch discon.	Poles - capacity	4x4000 A	4x2000 A	4x1600 A	4x400 A	4x100 A	4x800 A	4x630 A	4x400 A	4x250 A	4x160 A

Circuit		I16	I18						
Circuit-breaker	Type	Isomax S7 H	Emax E2 N						
or switch discon.	Poles - capacity	4x1600 A	4x1600 A						

GENERAL STANDARDS AND CHARACTERISTICS

VERIFYING THE OVERTEMPATURES

PROTECTION AGAINST SHORT-CIRCUIT AND ELECTRIC SHOCKS

PRACTICAL INDICATIONS AND CERTIFICATION AND CONSTRUCTION

CERTIFICATES

DECLARATION OF CONFORMITY



# Annex A: LOVAG ACAE certificates

GENERAL STANDARDS AND CHARACTERISTICS

VERIFYING THE OVERTEMPERATURES

PROTECTION AGAINST SHORT-CIRCUIT AND ELECTRIC SHOCKS

PRACTICAL INDICATIONS CERTIFICATION AND CONSTRUCTION

CERTIFICATES

DECLARATION OF CONFORMITY

**ASSOCIAZIONE PER LA CERTIFICAZIONE DELLE APPARECCHIATURE ELETTRICHE**  
**LOVAG**

Via Tito Livio, 5 - 24123 - BERGAMO (Italy)  
 tel. +390354775244 fax. +390354534662 e-mail: accaer@tin.it

### Certificate of Conformity

LOVAG Certificate No. **IT 03.072**  
 page 1 of 2

**Apparatus**  
 Low voltage switchgear assembly - 3 phases + neutral - 415 V (U<sub>n</sub>) - 690 V (U<sub>e</sub>) - frequency 50 Hz

**Designation**  
**ArTu K**

**Manufacturer or responsible vendor**  
**ABB SACE S.p.A.**, Automation and Distribution Boards Division -  
 Via Italia, 58 - 23846 Garbagnate Monastero (LC) Italy

**Tested for: ABB SACE S.p.A.**  
**Tested by: ACAE Laboratory IA.01**

The apparatus, constructed in accordance with the description mentioned in the Test Report listed on this Certificate has been subjected to the series of proving tests in accordance with IEC/EN 60439-1:1994, CEI-EN 60439-1:2000-11

The results are shown in the Test Report in accordance to LOVAG. The values obtained and the general performance are considered to comply with the above Standard(s) and to justify the characteristics assigned by the manufacturer as stated below.

- Verification of temperature rise limits:  
 Rated diversity factor = 1
- Verification of the dielectric properties (declared U<sub>imp</sub> = 6 kV)
- Verification of the short circuit withstand strength
- Verification of the effectiveness of the protective circuit

This document includes Report No.: 03.029  
 Issue Date: 2003.03.27

**Responsible Certification Body**

*Walter Merlo*  
 Authorized Signature  
 Date: 2003.04.03

**ASSOCIAZIONE PER LA CERTIFICAZIONE DELLE APPARECCHIATURE ELETTRICHE**  
**LOVAG**

Via Tito Livio, 5 - 24123 - BERGAMO (Italy)  
 tel. +390354775244 fax. +390354534662 e-mail: accaer@tin.it

### Certificate of Conformity

LOVAG Certificate No. **IT 03.072**  
 Page 2 of 2

**Circuit characteristics**

Circuit	Rated current I <sub>n</sub>	Rated short-circuit withstand current I <sub>cs</sub> (kA)	Rated withstanding current I <sub>wt</sub> (kA)	Rated available short-circuit current I <sub>sc</sub> (kA)
1.0	2250	50	110	50
1.1	1098			50
1.2.1.3				
1.4.1.5	113			50
1.6.1.7				
1.8.1.9	175			50
1.9.1.11	95			50
1.12	173			50
1.13	350			50
1.14.1.15	95			50
1.16	173			50
1.17	350			50
1.18	125			50
1.19	200			50
1.20	320			50
1.21	450			50
1.22	640			50

**Responsible Certification Body**

*Walter Merlo*  
 Authorized Signature  
 Date: 2003.04.03

## Annex A: LOVAG ACAE certificates

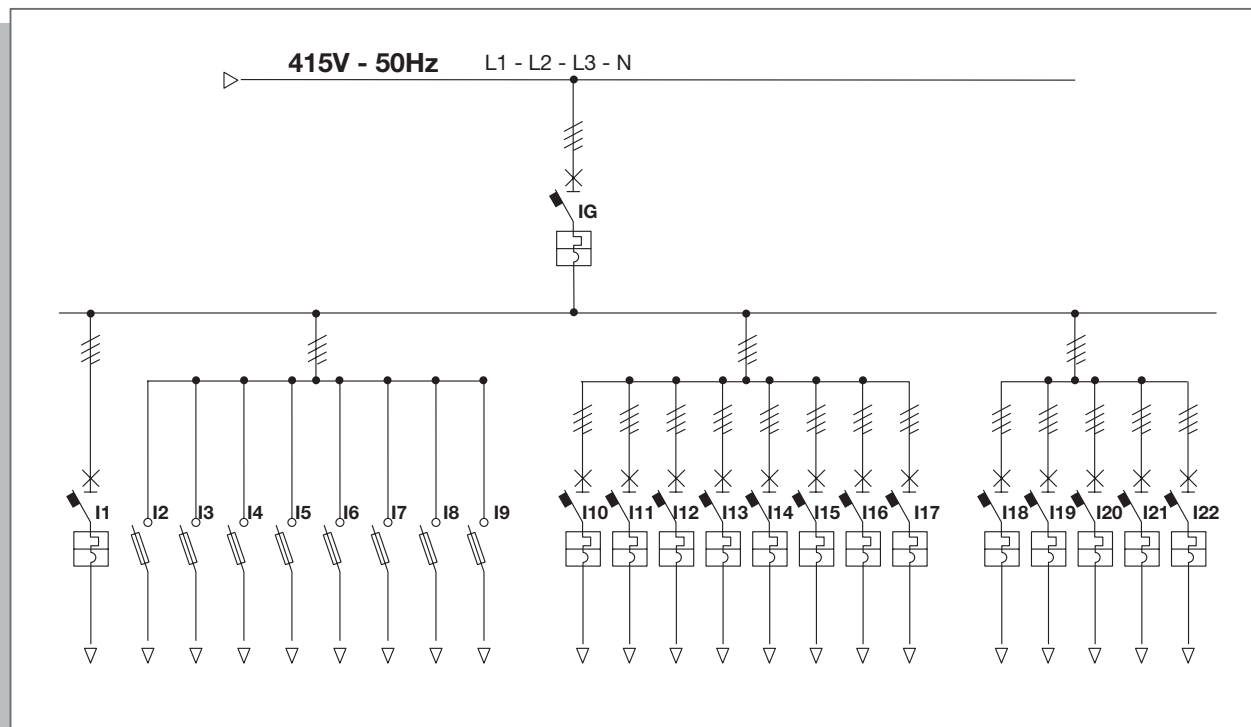
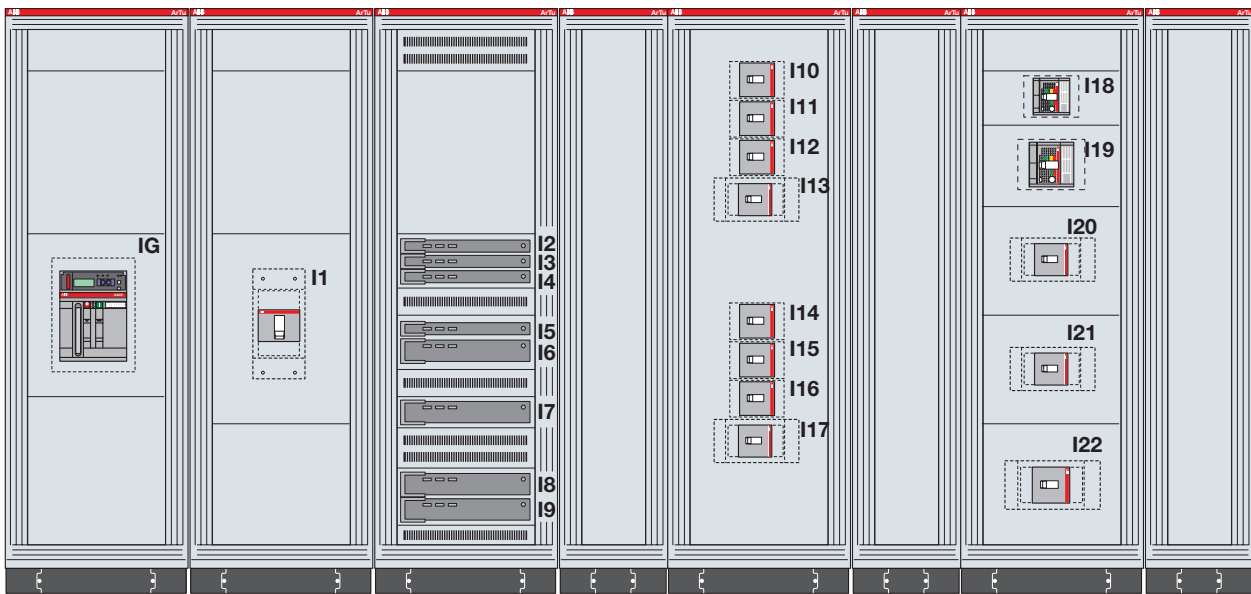

Circuit		IG	I1	I2 ÷ I5	I6 ÷ I9	I10-11	I12	I13	I14-15	I16	I17
Circuit-breaker	Type	Emax E3 S	Isomax S7 L	Slimline	Slimline	Isomax S2 S	Isomax S3 H	Isomax S5 H	Isomax S2 S	Isomax S3 H	Isomax S5 H
or switch disconn.	Poles - capacity	4x3200 A	4x1250 A	160 A	250 A	3x160 A	3x250 A	3x500 A	3x160 A	3x250 A	3x500 A
Circuit		I18	I19	I20	I21	I22					
Circuit-breaker	Type	Tmax T2 S	Tmax T3 S	Isomax S5 H	Isomax S5 H	Isomax S6 L					
or switch disconn.	Poles - capacity	4x250 A	4x250 A	4x400 A	4x500 A	4x800 A					

GENERAL STANDARDS AND CHARACTERISTICS

VERIFYING THE OVERTEMPATURES

PROTECTION AGAINST SHORT-CIRCUIT AND ELECTRIC SHOCKS

PRACTICAL INDICATIONS CERTIFICATION AND CONSTRUCTION

CERTIFICATES

DECLARATION OF CONFORMITY

► Annex A: LOVAG ACAE certificates

GENERAL STANDARDS AND CHARACTERISTICS

VERIFYING THE OVERTEMPERATURES

PROTECTION AGAINST SHORT-CIRCUIT AND ELECTRIC SHOCKS

PRACTICAL INDICATIONS CERTIFICATION AND CONSTRUCTION

CERTIFICATES

DECLARATION OF CONFORMITY

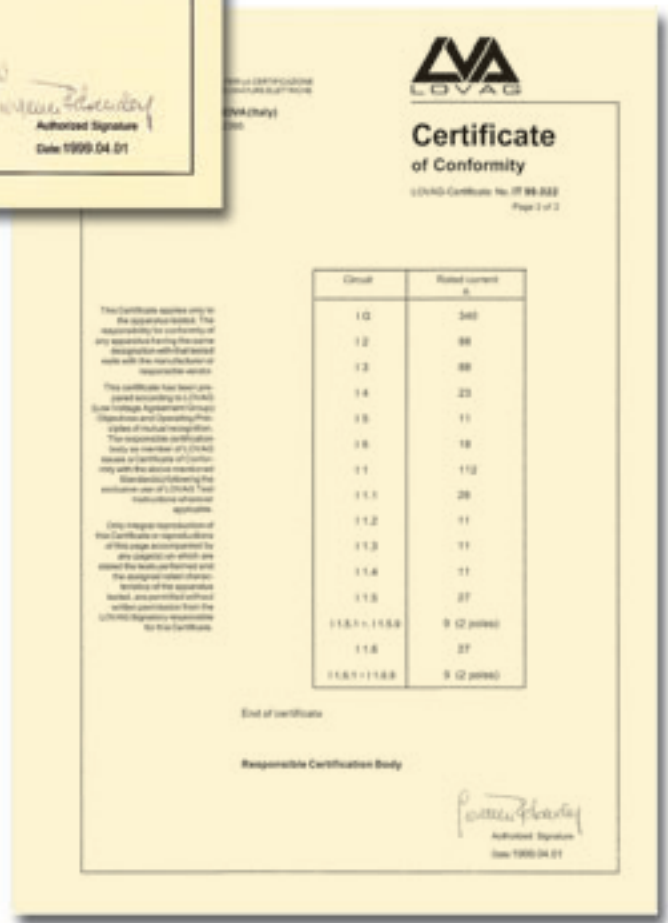
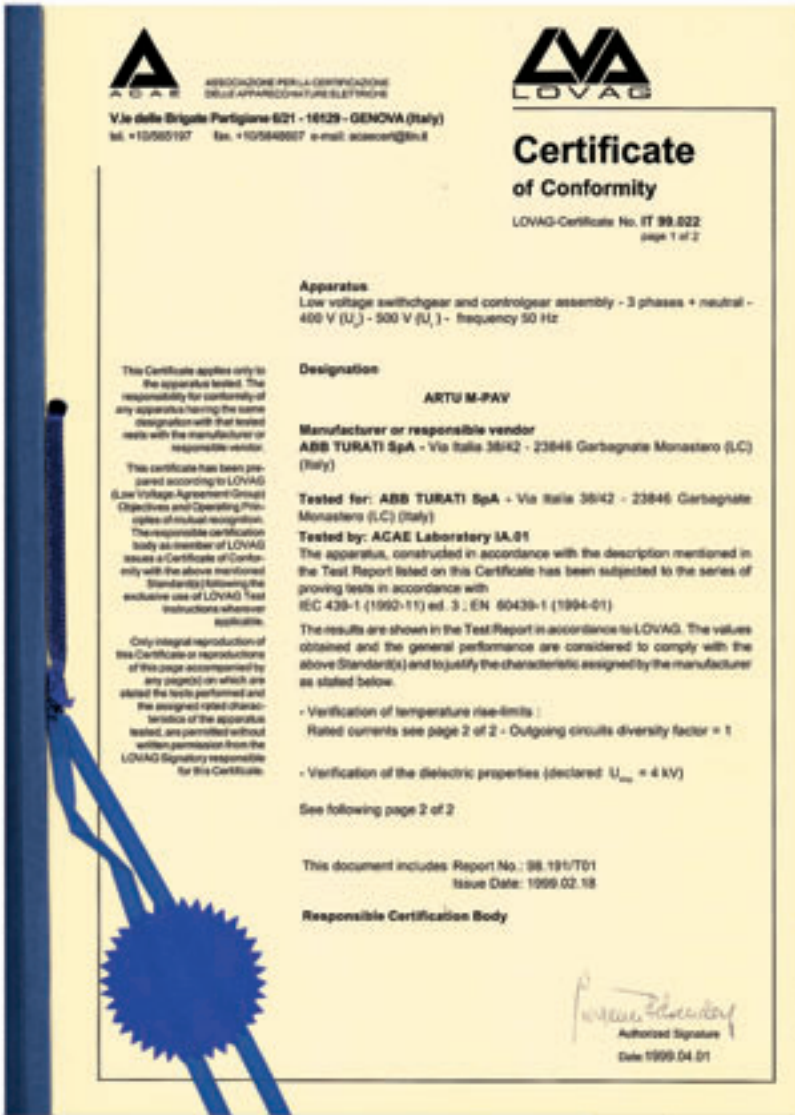

## ► Annex A: LOVAG ACAE certificates

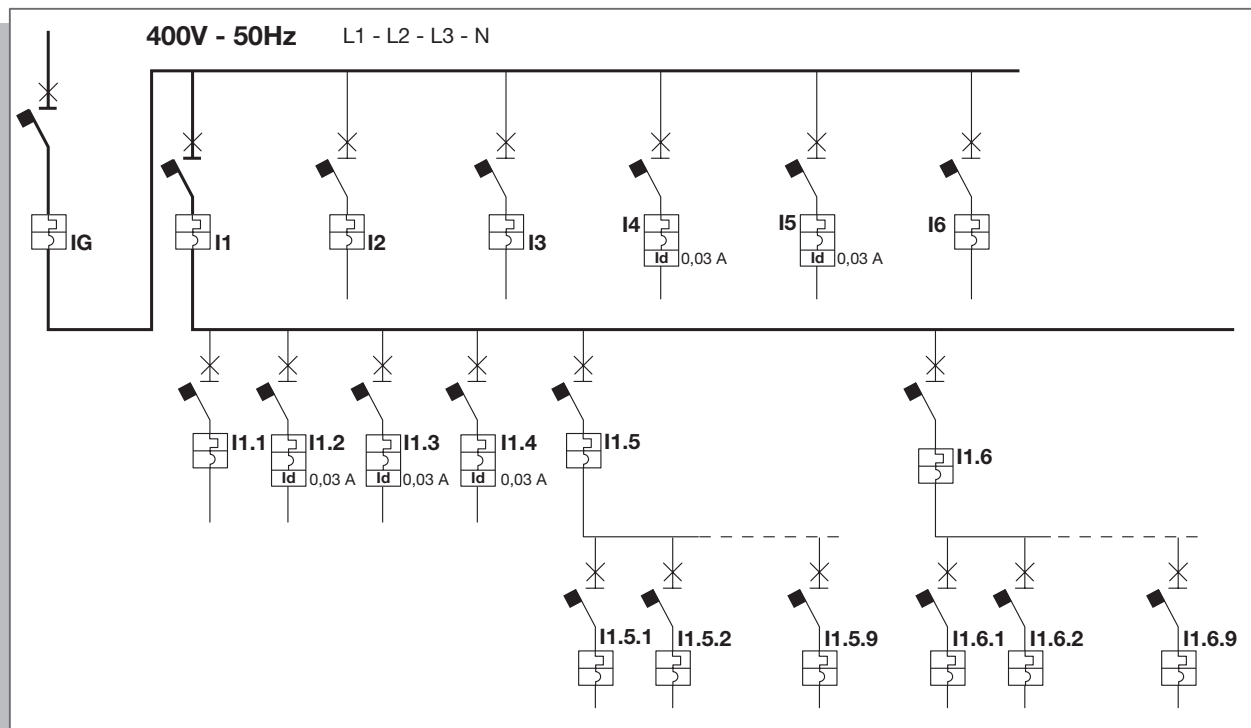
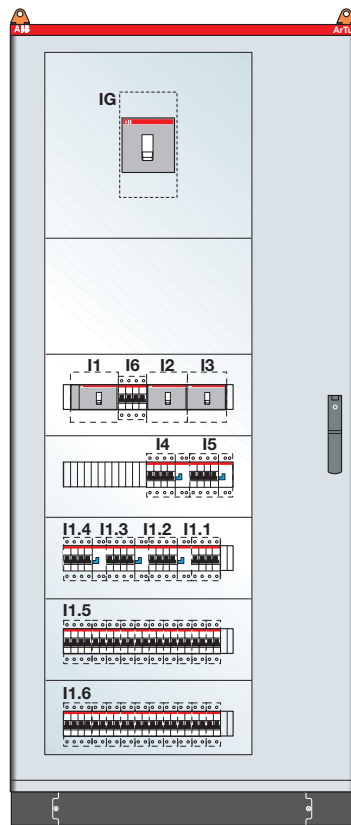

Circuit		IG	I1	I2-3	I4	I5	I6	I1.1	I1.2 + I1.4	I1.5	I1.5.1 + I1.5.9
Circuit-breaker or switch discon.	Type	Isomax S5 N	Isomax S2 N	Isomax S1 N	Pro-M S284	Pro-M S284	Pro-M S284	Pro-M S284	Pro-M S284	Pro-M S284	Pro-M S282
	Poles - capacity	4x400 A	4x160 A	4x125 A	C32 + DDA	C16 + DDA	C25	C40	C16 + DDA	C32	C10
Circuit		I1.6	I1.6.1 + I1.6.9								
Circuit-breaker or switch discon.	Type	Pro-M S284	Pro-M S282								
	Poles - capacity	C32	C10								

GENERAL  
STANDARDS AND  
CHARACTERISTICS

VERIFYING THE  
OVERTEMPATURES

PROTECTION AGAINST  
SHORT-CIRCUIT AND  
ELECTRIC SHOCKS

PRACTICAL INDICATIONS  
CERTIFICATION AND  
CONSTRUCTION

CERTIFICATES

DECLARATION OF  
CONFORMITY

# Annex A: LOVAG ACAE certificates

GENERAL STANDARDS AND CHARACTERISTICS

VERIFYING THE OVERTEMPERATURES

PROTECTION AGAINST SHORT-CIRCUIT AND ELECTRIC SHOCKS

PRACTICAL INDICATIONS CERTIFICATION AND CONSTRUCTION

CERTIFICATES

DECLARATION OF CONFORMITY

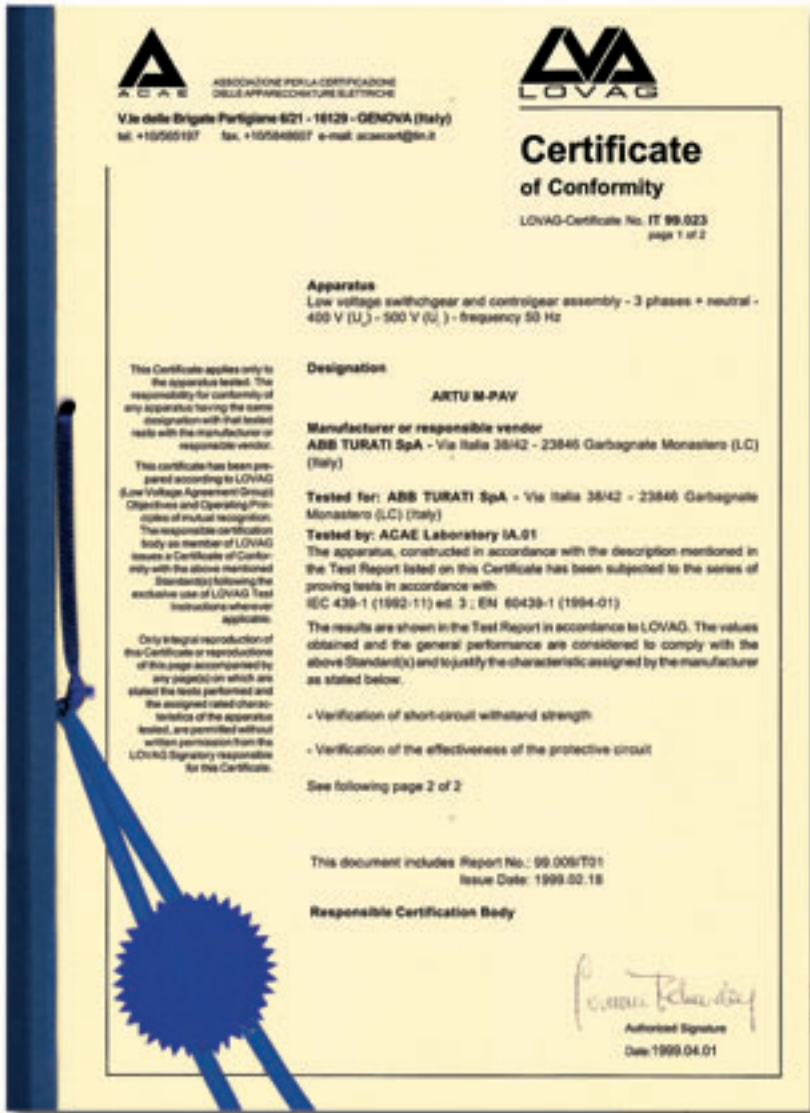

**ACA E** ASSOCIAZIONE PER LA CERTIFICAZIONE DELLE APPARECCHIATURE ELETTRICHE  
 Via delle Brigate Partigiane 6/21 - 16129 - GENOVA (Italy)  
 tel. +390501937 fax. +3905848027 e-mail. acaecon@tin.it

**LOVAG**

## Certificate of Conformity

LOVAG-Certificate No. IT 99.023  
 page 1 of 2

**Apparatus**  
 Low voltage switchgear and controlgear assembly - 3 phases + neutral - 400 V (U<sub>n</sub>) - 500 V (U<sub>i</sub>) - frequency 50 Hz

**Designation**  
**ARTU M-PAY**

**Manufacturer or responsible vendor**  
**ABB TURATI SpA - Via Italia 38/42 - 23846 Garbagnate Monastero (LC) (Italy)**

**Tested for:** ABB TURATI SpA - Via Italia 38/42 - 23846 Garbagnate Monastero (LC) (Italy)

**Tested by:** ACAE Laboratory IA.01  
 The apparatus, constructed in accordance with the description mentioned in the Test Report listed on this Certificate has been subjected to the series of proving tests in accordance with IEC 439-1 (1992-11) ed. 3 ; EN 60439-1 (1994-01)

The results are shown in the Test Report in accordance with LOVAG. The values obtained and the general performance are considered to comply with the above Standard(s) and to justify the characteristic assigned by the manufacturer as stated below.

- Verification of short-circuit withstand strength
- Verification of the effectiveness of the protective circuit

See following page 2 of 2

This document includes Report No.: 99.008/T01  
 Issue Date: 1999.02.18

**Responsible Certification Body**

*Paolo Polverini*  
 Authorized Signature  
 Date: 1999.04.01

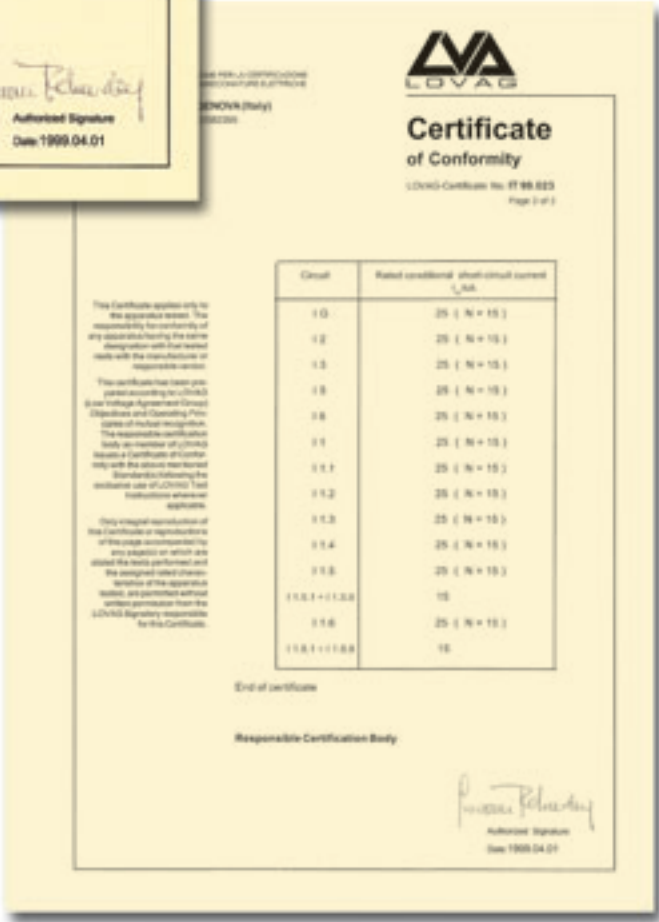

**LOVAG**

## Certificate of Conformity

LOVAG-Certificate No. IT 99.023  
 Page 2 of 2

Circuit	Rated conditional short-circuit current I <sub>sc</sub> kA
1.0	25 (N = 15)
1.2	25 (N = 15)
1.3	25 (N = 15)
1.5	25 (N = 15)
1.6	25 (N = 15)
1.1	25 (N = 15)
1.1.1	25 (N = 15)
1.1.2	25 (N = 15)
1.1.3	25 (N = 15)
1.1.4	25 (N = 15)
1.1.5	25 (N = 15)
1.1.1 + 1.1.2	15
1.1.6	25 (N = 15)
1.1.1 + 1.1.6	15

End of certificate

**Responsible Certification Body**

*Paolo Polverini*  
 Authorized Signature  
 Date: 1999.04.01

## ► Annex A: LOVAG ACAE certificates

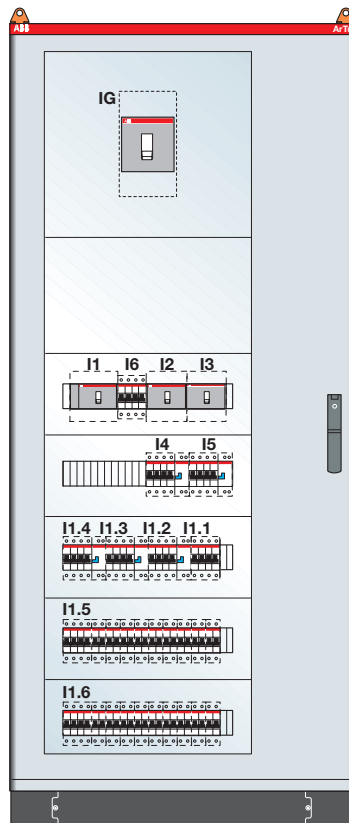

GENERAL STANDARDS AND CHARACTERISTICS

VERIFYING THE OVERTEMPATURES

PROTECTION AGAINST SHORT-CIRCUIT AND ELECTRIC SHOCKS

PRACTICAL INDICATIONS AND CERTIFICATION AND CONSTRUCTION

CERTIFICATES

DECLARATION OF CONFORMITY

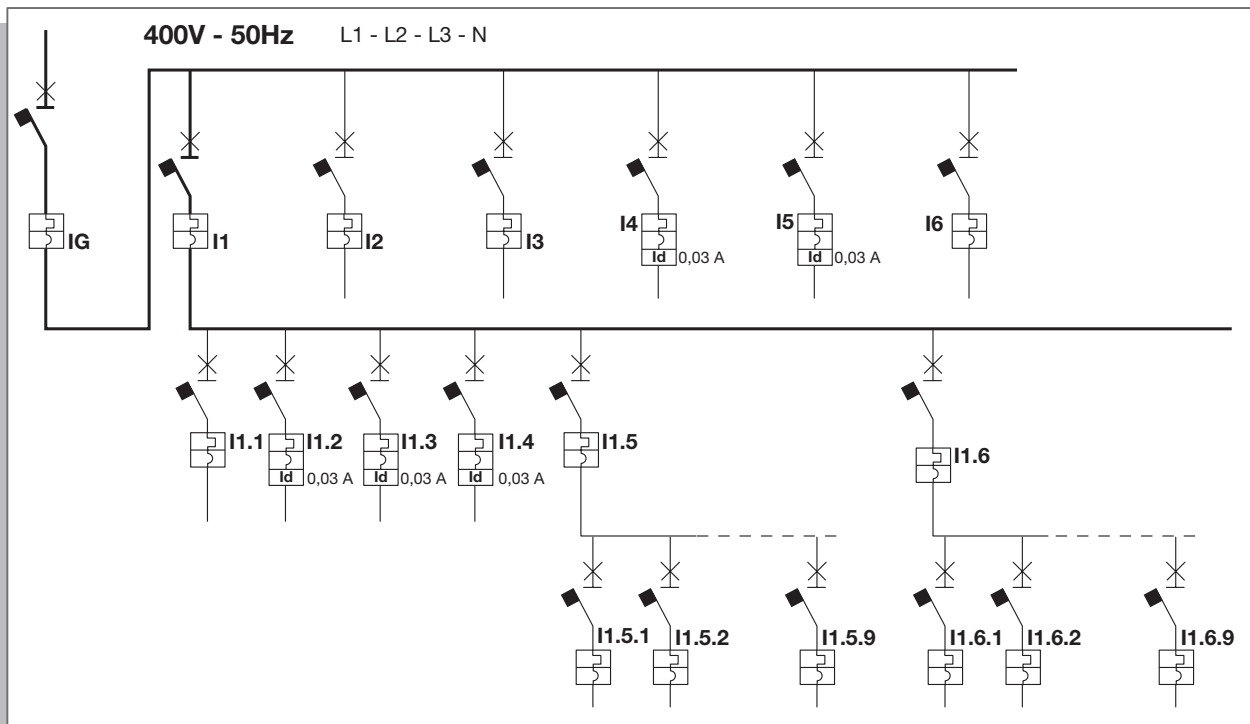

Circuit		IG	I1	I2-3	I4	I5	I6	I1.1	I1.2 + I1.4	I1.5	I1.5.1 + I1.5.9
Circuit-breaker or switch discon.	Type	Isomax S5 N	Isomax S2 N	Isomax S1 N	Pro-M S284	Pro-M S284	Pro-M S284	Pro-M S284	Pro-M S284	Pro-M S284	Pro-M S282
	Poles - capacity	4x400 A	4x160 A	4x125 A	C32 + DDA	C16 + DDA	C25	C40	C16 + DDA	C32	C10
Circuit		I1.6	I1.6.1 + I1.6.9								
Circuit-breaker or switch discon.	Type	Pro-M S284	Pro-M S282								
	Poles - capacity	C32	C10								

# Annex A: LOVAG ACAE certificates

GENERAL STANDARDS AND CHARACTERISTICS

VERIFYING THE OVERTEMPERATURES

PROTECTION AGAINST SHORT-CIRCUIT AND ELECTRIC SHOCKS

PRACTICAL INDICATIONS CERTIFICATION AND CONSTRUCTION

CERTIFICATES

DECLARATION OF CONFORMITY



**ACAE**  
ASSOCIAZIONE PER LA CERTIFICAZIONE  
DELLE APPARECCHIATURE ELETTRICHE

V.le delle Brigate Partigiane 621 - 16125 - GENOVA (Italy)  
tel. +390551937 fax. +390548627 e-mail: acaser@tin.it



**LOVAG**

## Certificate of Conformity

LOVAG-Certificate No. IT 99.024  
page 1 of 2

**Apparatus**  
Low voltage switchgear and controlgear assembly - 3 phases + neutral - 400 V (U<sub>j</sub>) - 500 V (U<sub>i</sub>) - frequency 50 Hz

**Designation**  
**ARTU M-PAR**

**Manufacturer or responsible vendor**  
**ABB TURATI SpA - Via Italia 3542 - 23845 Garbagnate Monastero (LC) (Italy)**

**Tested for:** ABB TURATI SpA - Via Italia 3542 - 23845 Garbagnate Monastero (LC) (Italy)

**Tested by:** ACAE Laboratory IA.01

The apparatus, constructed in accordance with the description mentioned in the Test Report listed on this Certificate has been subjected to the series of proving tests in accordance with IEC 439-1 (1992-11) ed. 3 ; EN 60439-1 (1994-01)

The results are shown in the Test Report in accordance to LOVAG. The values obtained and the general performance are considered to comply with the above Standard(s) and its justify the characteristic assigned by the manufacturer as stated below.

- Verification of temperature rise-limits  
Rated currents see page 2 of 2 - Outgoing circuits diversity factor = 1
- Verification of short-circuit withstand strength
- Verification of the effectiveness of the protective circuit
- Verification of the dielectric properties (declared U<sub>imp</sub> = 4 kV)

See following page 2 of 2

This document includes Report No. 99.1921701  
Issue Date: 1999.03.19

**Responsible Certification Body**

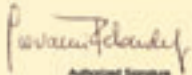
  
 Authorized Signature  
 Date: 1999.04.01



**LOVAG**

## Certificate of Conformity

LOVAG-Certificate No. IT 99.024  
Page 2 of 2

Circuit	Rated current A	Rated conditional short-circuit current I <sub>cs</sub> kA
1.0	125	10 (N + S)
1.1	25	10 (N + S)
1.2	25	10 (N + S)
1.3	13	10 (N + S)
1.4	8 (2 poles)	8
1.5	8 (2 poles)	8
1.6	8 (2 poles)	8
1.7	8 (2 poles)	8
1.8	8 (2 poles)	8
1.9	8 (2 poles)	8
1.10	25	10 (N + S)
1.10.1 + 1.10.0	8 (2 poles)	8
1.11	25	10 (N + S)
1.11.1 + 1.11.0	8 (2 poles)	8

End of certificate

**Responsible Certification Body**

  
 Authorized Signature  
 Date: 1999.04.01

## Annex A: LOVAG ACAE certificates

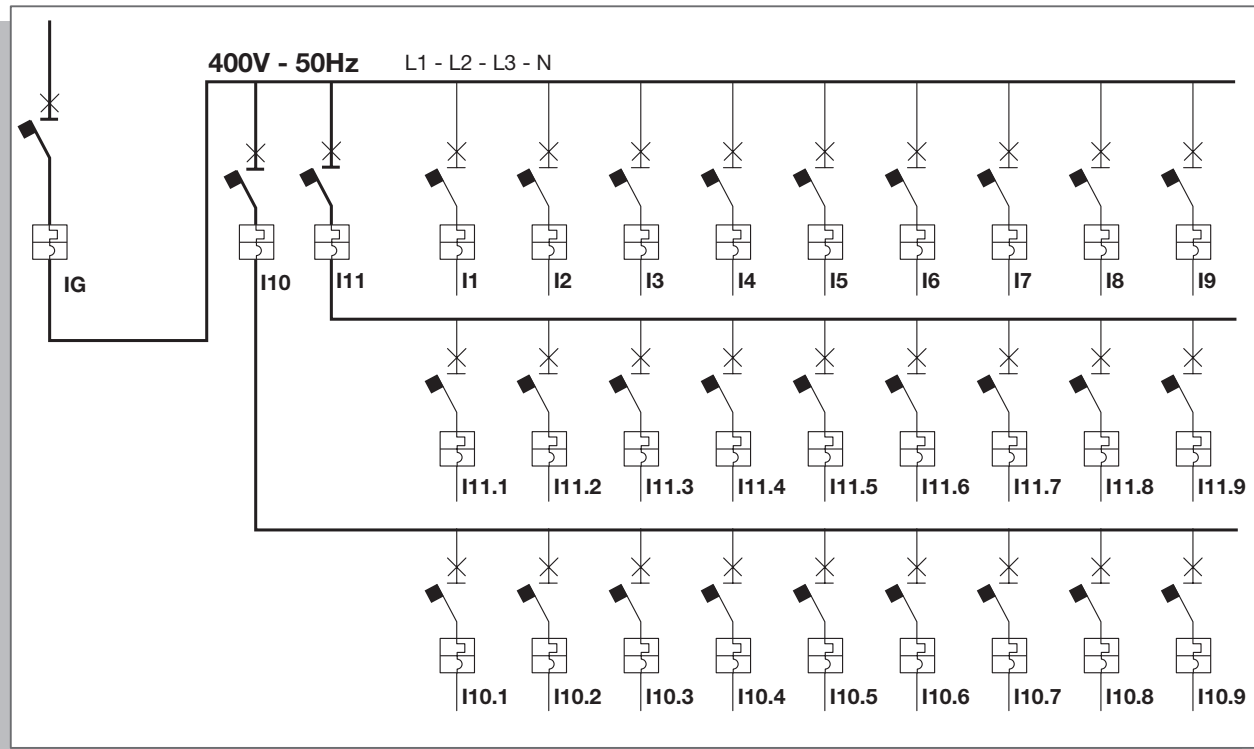
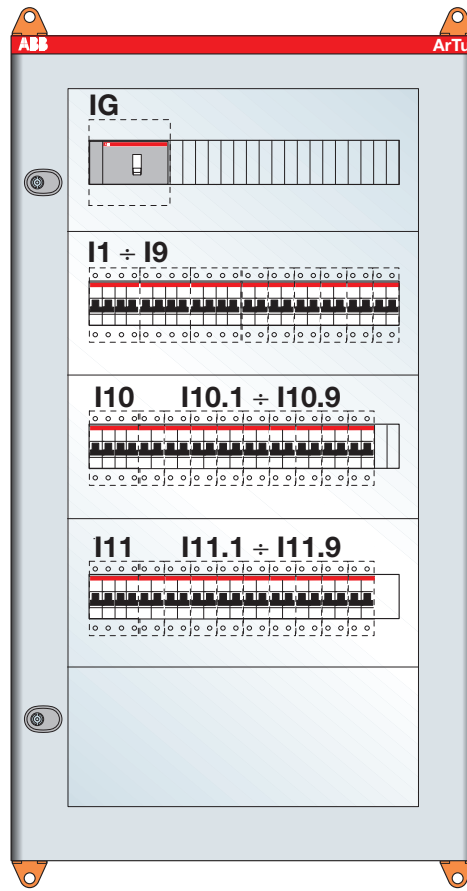

Circuit		IG	I1	I2	I3	I4 ÷ I9	I10	I10.1 ÷ I10.9	I11	I11.1 ÷ I11.9
Circuit-breaker or switch discon.	Type	Isomax S2 N	Pro-M S274	Pro-M S274	Pro-M S274	Pro-M S271	Pro-M S274	Pro-M S271	Pro-M S274	Pro-M S271
	Poles - capacity	4x160 A	C32	C25	C16	C10	C32	C10	C32	C10

GENERAL  
STANDARDS AND  
CHARACTERISTICS

VERIFYING THE  
OVERTEMPATURES

PROTECTION AGAINST  
SHORT-CIRCUIT AND  
ELECTRIC SHOCKS

PRACTICAL INDICATIONS  
CERTIFICATION AND  
CONSTRUCTION

CERTIFICATES

DECLARATION OF  
CONFORMITY



# Annex A: LOVAG ACAE certificates

GENERAL STANDARDS AND CHARACTERISTICS

VERIFYING THE OVERTEMPERATURES

PROTECTION AGAINST SHORT-CIRCUIT AND ELECTRIC SHOCKS

PRACTICAL INDICATIONS CERTIFICATION AND CONSTRUCTION

CERTIFICATES

DECLARATION OF CONFORMITY

**ACA E** ASSOCIAZIONE PER LA CERTIFICAZIONE DELLE APPARECCHIATURE ELETTRICHE  
Via Tito Livio, 5 - 24123 - BERGAMO (Italy)  
tel. +390354175244 fax. +390354534662 e-mail: accert@aca.e

**LOVAG**

## Certificate of Conformity

LOVAG Certificate No. IT03.099  
page 1 of 2

**Apparatus**  
Low voltage switchgear assembly - 3 phases + neutral - 400 V (U<sub>n</sub>) - 500 V (U<sub>i</sub>) - frequency 50 Hz

**Designation**  
ArTu L

**Manufacturer or responsible vendor**  
ABB SACE S.p.A. Automation and Distribution Boards Division - Via Italia, 58 - 23846 Garbagnate Monastero (LC) Italy

**Tested for: ABB SACE S.p.A.**  
**Tested by: ACAE Laboratory IA.01**

The apparatus, constructed in accordance with the description mentioned in the Test Report listed on this Certificate has been subjected to the series of proving tests in accordance with IEC/EN 60439-1:1999, CEI/EN 60439-1:2000-11.

The results are shown in the Test Report in accordance to LOVAG. The values obtained and the general performance are considered to comply with the above Standard(s) and to justify the characteristic assigned by the manufacturer as stated below.

- Verification of temperature rise limits:  
Rated diversity factor = 1
- Verification of the dielectric properties (declared: U<sub>imp</sub> = 4 kV)
- Verification of the short-circuit withstand strength
- Verification of the effectiveness of the protective circuit
- Verification of the clearance and creepage distances

This document includes Report No.: 03.027  
Issue Date: 2003.05.26

Responsible Certification Body: ACAE

**SINCERT**  
P.O. BOX 1000 - 20131 Milano - Italy  
Representative of IEC and CEI Mutual Recognition Agreements

Mauro Marini  
Authorized Signature  
Date: 2003.06.26

**LOVAG**

## Certificate of Conformity

LOVAG Certificate No. IT03.099  
Page 2 of 2

**Circuit characteristics:**

Circuit	Rated current I <sub>n</sub>	Rated conditional short-circuit current I <sub>cs</sub> kA
1.0	630	20
1.1	125	10
1.2	75	10
1.3	120	10
1.4	100	10
1.4.1	20	10
1.4.2	20	10
1.4.3	20	10
1.4.4	20	10
1.4.5	20	10
1.5	80	10
1.6	80	10

Responsible Certification Body: ACAE

**SINCERT**  
P.O. BOX 1000 - 20131 Milano - Italy  
Representative of IEC and CEI Mutual Recognition Agreements

Mauro Marini  
Authorized Signature  
Date: 2003.06.26

## ► Annex A: LOVAG ACAE certificates

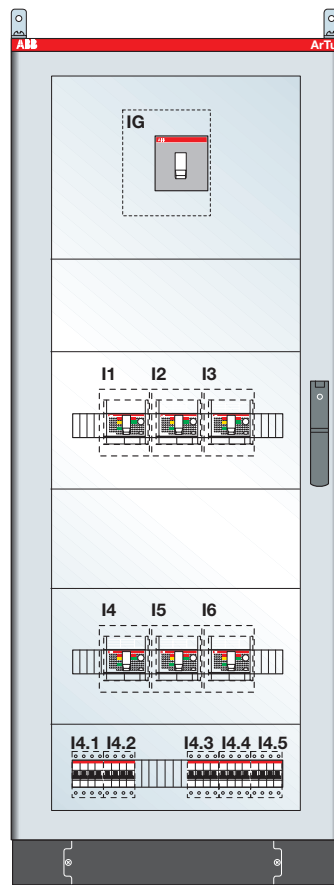

GENERAL  
STANDARDS AND  
CHARACTERISTICS

VERIFYING THE  
OVERTEMPATURES

PROTECTION AGAINST  
SHORT-CIRCUIT AND  
ELECTRIC SHOCKS

PRACTICAL INDICATIONS  
CERTIFICATION AND  
CONSTRUCTION

CERTIFICATES

DECLARATION OF  
CONFORMITY

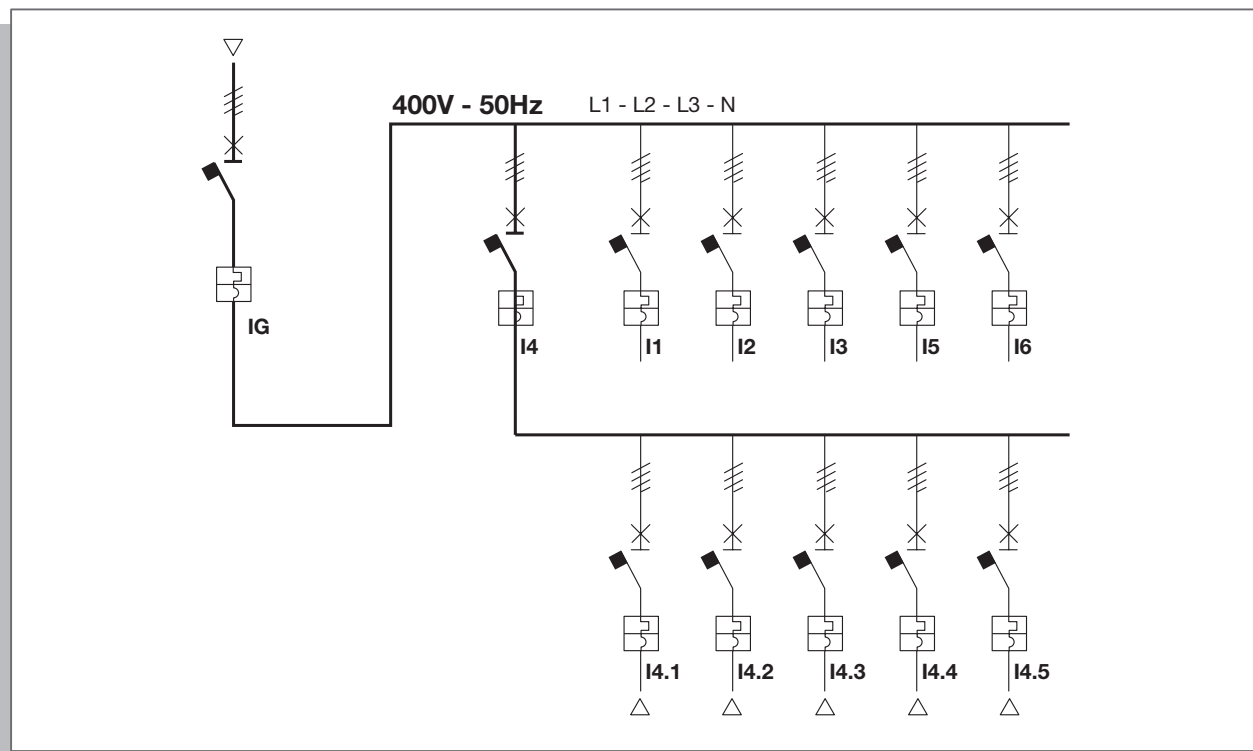

Circuit		IG	I1	I2	I3-I4	I5	I6	I4.1 + I4.4	I4.5		
Circuit-breaker	Type	Isomax S6 N	Tmax T3 N	Tmax T1 N	Tmax T1 N	Tmax T2 S	Tmax T2 N	Pro-M S274	Pro-M S284		
or switch discon.	Poles - capacity	4x800 A	4x250 A	4x125 A	4x160 A	4x160 A	4x160 A	C25	C20		

► Annex A: LOVAG ACAE certificates

GENERAL STANDARDS AND CHARACTERISTICS

VERIFYING THE OVERTEMPERATURES

PROTECTION AGAINST SHORT-CIRCUIT AND ELECTRIC SHOCKS

PRACTICAL INDICATIONS CERTIFICATION AND CONSTRUCTION

CERTIFICATES

DECLARATION OF CONFORMITY

**ACAЕ** ASSOCIAZIONE PER LA CERTIFICAZIONE DELLE APPARECCHIATURE ELETTRICHE  
Via Tito Livio, 5 - 24123 - BERGAMO (Italy)  
tel. +390354175244 fax. +390354534662 e-mail. accaer@tin.it

**LOVAG**

### Certificate of Conformity

LOVAG Certificate No. **IT03.131**  
page 1 of 2

**Apparatus**  
Low voltage switchgear assembly - 3 phases + neutral - 690 V (U<sub>n</sub>) - 800 V (U<sub>i</sub>) - frequency 50 Hz

**Designation**  
**ArTu L**

**Manufacturer or responsible vendor**  
**ABB SACE S.p.A.** Automation and Distribution Boards Division - Via Italia, 58 - 23846 Garbagnate Monastero (LC) Italy

**Tested for: ABB SACE S.p.A.**  
**Tested by: ACAE Laboratory IA.01**

The apparatus, constructed in accordance with the description mentioned in the Test Report listed on this Certificate has been subjected to the series of proving tests in accordance with IEC/EN 60439-1:2000, CEI/EN 60439-1:2000-11.

The results are shown in the Test Report in accordance to LOVAG. The values obtained and the general performance are considered to comply with the above Standard(s) and to justify the characteristic assigned by the manufacturer as stated below:

- B.2.3 Verification of the short-circuit withstand strength  $I_{sc} = 35kA$
- B.2.4.2 Verification of the short-circuit strength of the protective circuit by test  $I_{sc} = 21kA$

This document includes Report No.: 03.028  
Issue Date: 2003.09.22

Responsible Certification Body: **ACAЕ**

**SINCERT**  
PROFESIONISTI IN  
Regulatory and/or Mutual Recognition Agreements

*Walter Marchi*  
Walter Marchi  
Authorized Signature  
Date: 2003.11.25

**LOVAG**

### Certificate of Conformity

LOVAG Certificate No. **IT03.131**  
Page 2 of 2

**ACAЕ** ASSOCIAZIONE PER LA CERTIFICAZIONE DELLE APPARECCHIATURE ELETTRICHE  
Via Tito Livio, 5 - 24123 - BERGAMO (Italy)  
tel. +390354175244 fax. +390354534662 e-mail. accaer@tin.it

**Responsible Certification Body: ACAЕ**

**SINCERT**  
PROFESIONISTI IN  
Regulatory and/or Mutual Recognition Agreements

*Walter Marchi*  
Walter Marchi  
Authorized Signature  
Date: 2003.11.25

Circuit characteristics:

Circuit	Rated conditional short-circuit current $I_{sc}$ (kA)
I 0	35
I 1	35
I 2	35
I 3	35
I 5	35

## ► Annex A: LOVAG ACAE certificates

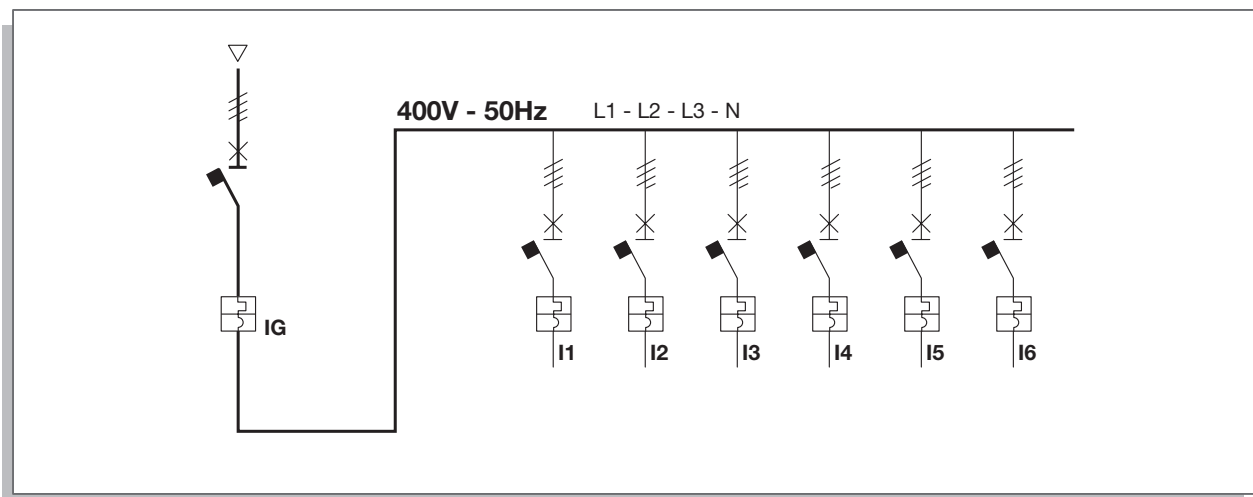
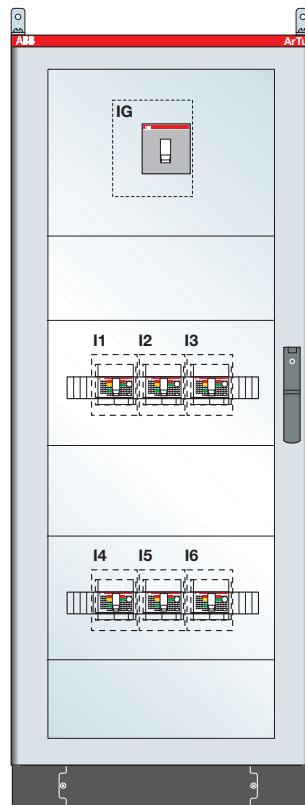

Circuit		IG	I1	I2	I3-I4	I5	I6			
Circuit-breaker or switch discon.	Type	Isomax S6 N	Tmax T3 N	Tmax T1 N	Tmax T1 N	Tmax T2 S	Tmax T2 N			
	Poles - capacity	4x800 A	4x250 A	4x125 A	4x160 A	4x160 A	4x160 A			

GENERAL  
STANDARDS AND  
CHARACTERISTICS

VERIFYING THE  
OVERTEMPATURES

PROTECTION AGAINST  
SHORT-CIRCUIT AND  
ELECTRIC SHOCKS

PRACTICAL INDICATIONS  
CERTIFICATION AND  
CONSTRUCTION

CERTIFICATES

DECLARATION OF  
CONFORMITY

## ► Annex B: forms for the declaration of conformity and testing

### DECLARATION OF CONFORMITY ELECTRIC SWITCHGEAR FOR LOW VOLTAGE IN ACCORDANCE WITH IEC 60439-1 (EN 60439-1)

The company.....

With head office in.....

Builder of the switchgear.....

.....

Taking full responsibility for this, declares that the switchgear described above has been constructed by us with good workmanship and in conformity with all the specifications foreseen by the IEC 60439-1 Standard.

Also declares that ABB SACE components were used, and respect was paid to the selection criteria and assembly instructions indicated in the relative catalogues and on the instruction sheets, and that the performances of the material used declared in the above-mentioned catalogues were in no way jeopardised during assembly or by means of modifications.

These performances and the verifications carried out therefore allow us to declare conformity of the switchgear in question with the following requirements in the Standard:

Overtemperature ..... (ref. 8.2.1.)

Voltage withstand..... (ref. 8.2.2.)

Short-circuit withstand..... (ref. 8.2.3.)

Efficiency of the protection circuit ..... (ref. 8.2.4.)

Air and surface distances..... (ref. 8.2.5.)

Operation ..... (ref. 8.2.6.)

Degree of protection ..... (ref. 8.2.7.)

Finally, taking responsibility for this, declares that they have carried out all the individual tests foreseen by the Standard with a positive outcome, and more precisely:

Cabling and electrical operation (ref. 8.3.1.)

Insulation (ref. 8.3.2.)

Protection measures (ref. 8.3.3.)

Insulation resistance (ref. 8.3.4.)

as an alternative to the applied voltage withstand test (ref.8.2.2. only for PTTA switchgear).

Date and Place .....

Signature.....

.....

.....  
(Full name and function of the person in charge of signing on behalf of the manufacturer)

► **Annex B: forms for the declaration of conformity and testing**

**TEST CERTIFICATE  
ELECTRIC SWITCHGEAR FOR LOW VOLTAGE – IN ACCORDANCE WITH THE  
INDIVIDUAL TESTS FORESEEN BY THE STANDARD IEC 60439-1 (EN 60439-1)**

The company.....

With head office in.....

Builder of the switchgear.....

.....

issues the

**TEST CERTIFICATE**

attesting with this document that all the technical verifications foreseen by the Standards applicable to the product and in particular those in the IEC 60439-1 Standard have been carried out, as well as that all the legal and statutory obligations required by the provisions in force have been fulfilled.

Date and Place.....

.....

Signature.....

.....

(Full name and function of the person in charge of signing on behalf of the manufacturer)

GENERAL  
STANDARDS AND  
CHARACTERISTICS

VERIFYING THE  
OVERTEMPERATURES

PROTECTION AGAINST  
SHORT-CIRCUIT AND  
ELECTRIC SHOCKS

PRACTICAL INDICATIONS  
CERTIFICATION AND  
CONSTRUCTION

CERTIFICATES

DECLARATION OF  
CONFORMITY

## ► Annex B: forms for the declaration of conformity and testing

### DECLARATION OF EC CONFORMITY ELECTRIC SWITCHGEAR FOR LOW VOLTAGE IN ACCORDANCE WITH IEC 60439-1 (EN 60439-1)

The company.....

With head office in.....

Builder of the switchgear.....

Declares, under their responsibility, that the switchgear

type.....

serial n°.....

last two figures of the year the marking was affixed.....

conforms to what is foreseen by the following European Community directives (including the latest modifications thereto), as well as to the relative national implementation legislation

Reference n°	Title
73/23/CEE	Low Voltage Directive
89/336/CEE e 92/31 CEE	Electromagnetic compatibility Directive <sup>(1)</sup>
93/68/CEE	CE Marking Directive

and that the following harmonized Standard was applied

n°edition		title	part
IEC 60439-1	IV	Low-voltage switchgear and controlgear assemblies Part 1: type tested and partially type-tested assemblies	1

<sup>(1)</sup> Omit this Directive in the cases where accordance with the same is not required.

Date and Place .....

Signature.....

.....  
(Full name and function of the person in charge of signing on behalf of the manufacturer)

## ► Annex B: forms for the declaration of conformity and testing

### TEST CHECK-LIST ACCORDING TO THE INDIVIDUAL TESTS

Customer.....

Plant .....

Confirmation n° .....

Checking Operation	Functional unit number										Outcome	
Visual inspections	x	x	x	x	x	x	x	x	x	x	x	not applicable
correspondence of the apparatus												
cross-section of the conductors												
busbar coating/treatment												
colour/appearance of the switchgear												
Mechanical checks												
tightening of connections (with sampling)												
power circuit												
secondary circuit												
earthing circuit												
locks and interlocks												
door closures												
basket adherence												
Electric checks on the circuits and apparatus												
operating mechanism												
protection												
lighting												
heating												
signalling												
meters												
measurement												
signalling lamps												
locking devices												
continuity of the exposed conductive parts												
Degree of protection												
Insulation test with voltage at power freq.												
Insulation voltage												
Test voltage												
Main circuits												
Auxiliary circuits												
Measurement of the insulation resistance 500V												
Reference documentation												
standards /specifications												
single-line diagram												
overall view												
front of switchgear												
diagram of auxiliaries												
other references												

GENERAL  
STANDARDS AND  
CHARACTERISTICS

VERIFYING THE  
OVERTEMPÉRATURES

PROTECTION AGAINST  
SHORT-CIRCUIT AND  
ELECTRIC SHOCKS

PRACTICAL INDICATIONS  
CERTIFICATION AND  
CONSTRUCTION

CERTIFICATES

DECLARATION OF  
CONFORMITY



## ► Annex B: forms for the declaration of conformity and testing

### INDIVIDUAL TEST REPORT (TESTING)

Customer.....

Plant .....

Order N° .....

#### Type and identification of the switchgear

Assembly drawing.....

Functional diagram.....

Other diagrams.....

Rated service voltage.....

Rated current of the input circuit.....

Individual tests carried out according to the IEC 60439-1		Outcome
Standard Ref. par.		
8.3.1	Inspection of the switchgear including the cabling check and, if necessary, a test of electrical operation	
8.3.2	Applied voltage test (as an alternative to 8.3.4)	
8.3.3	Checking the means of protection and electric continuity of the protection circuits	
8.3.4	Checking the insulation resistance (as an alternative to 8.3.2)	

Tests carried out at.....

In the presence of Mr.....

**Having passed the tests listed above, the above-mentioned switchgear is found to conform to the IEC 60439-1 Standard.**

**Алматы** (7273)495-231  
**Ангарск** (3955)60-70-56  
**Архангельск** (8182)63-90-72  
**Астрахань** (8512)99-46-04  
**Барнаул** (3852)73-04-60  
**Белгород** (4722)40-23-64  
**Благовещенск** (4162)22-76-07  
**Брянск** (4832)59-03-52  
**Владивосток** (423)249-28-31  
**Владикавказ** (8672)28-90-48  
**Владимир** (4922)49-43-18  
**Волгоград** (844)278-03-48  
**Вологда** (8172)26-41-59  
**Воронеж** (473)204-51-73  
**Екатеринбург** (343)384-55-89

**Иваново** (4932)77-34-06  
**Ижевск** (3412)26-03-58  
**Иркутск** (395)279-98-46  
**Казань** (843)206-01-48  
**Калининград** (4012)72-03-81  
**Калуга** (4842)92-23-67  
**Кемерово** (3842)65-04-62  
**Киров** (8332)68-02-04  
**Коломна** (4966)23-41-49  
**Кострома** (4942)77-07-48  
**Краснодар** (861)203-40-90  
**Красноярск** (391)204-63-61  
**Курск** (4712)77-13-04  
**Курган** (3522)50-90-47  
**Липецк** (4742)52-20-81

**Магнитогорск** (3519)55-03-13  
**Москва** (495)268-04-70  
**Мурманск** (8152)59-64-93  
**Набережные Челны** (8552)20-53-41  
**Нижний Новгород** (831)429-08-12  
**Новокузнецк** (3843)20-46-81  
**Ноябрьск** (3496)41-32-12  
**Новосибирск** (383)227-86-73  
**Омск** (3812)21-46-40  
**Орел** (4862)44-53-42  
**Оренбург** (3532)37-68-04  
**Пенза** (8412)22-31-16  
**Петрозаводск** (8142)55-98-37  
**Псков** (812)59-10-37  
**Пермь** (342)205-81-47

**Ростов-на-Дону** (863)308-18-15  
**Рязань** (4912)46-61-64  
**Самара** (846)206-03-16  
**Санкт-Петербург** (812)309-46-40  
**Саратов** (845)249-38-78  
**Севастополь** (8692)22-31-93  
**Саранск** (8342)22-96-24  
**Симферополь** (3652)67-13-56  
**Смоленск** (4812)29-41-54  
**Сочи** (862)225-72-31  
**Ставрополь** (8652)20-65-13  
**Сургут** (3462)77-98-35  
**Сыктывкар** (8212)25-95-17  
**Тамбов** (4752)50-40-97  
**Тверь** (4822)63-31-35

**Тольятти** (8482)63-91-07  
**Томск** (3822)98-41-53  
**Тула** (4872)33-79-87  
**Тюмень** (3452)66-21-18  
**Ульяновск** (8422)24-23-59  
**Улан-Удэ** (3012)59-97-51  
**Уфа** (347)229-48-12  
**Хабаровск** (4212)92-98-04  
**Чебоксары** (8352)28-53-07  
**Челябинск** (351)202-03-61  
**Череповец** (8202)49-02-64  
**Чита** (3022)38-34-83  
**Якутск** (4112)23-90-97  
**Ярославль** (4852)69-52-93

Россия +7(495)268-04-70

Казахстан +7(7172)727-132

Киргизия +996(312)96-26-47

<https://abbenclosures.nt-rt.ru/> || [aaa@nt-rt.ru](mailto:aaa@nt-rt.ru)